

Temperature Difference Controller

STDC

Installation and operating instructions

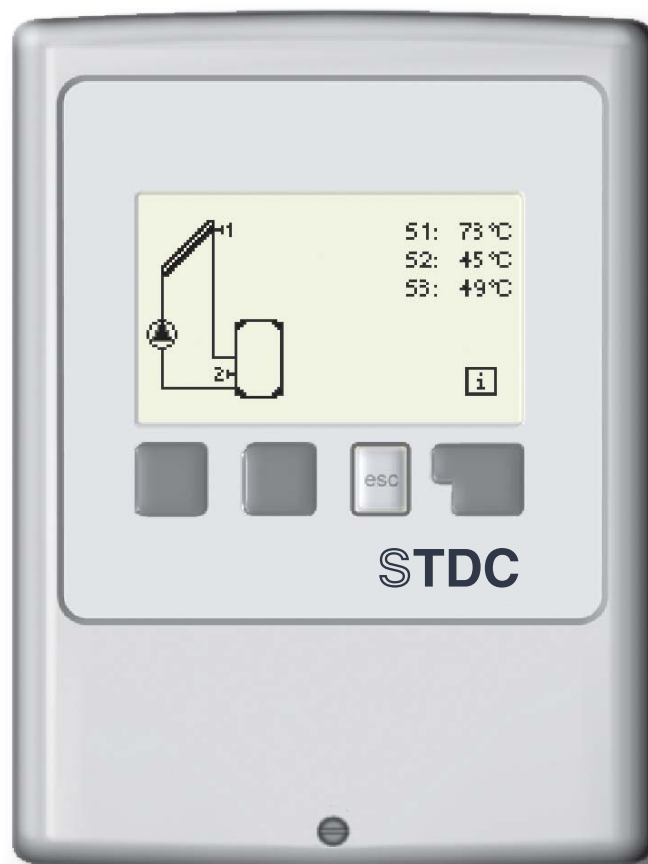

Read carefully before installation, commissioning and operation

Content

A.1	EC declaration of conformity	3	5. Settings	23
A.2	General instructions	3	5.1	Tmin S1 23
A.3	Explanation of symbols	3	5.2	Tmax S2 23
A.4	Changes to the unit	4	5.3	ΔT 24
A.5	Warranty and liability	4	5.4	Tref 24
			5.5	Thermostat times 25
B.1	Specifications	5	5.6	Party Funktion 25
B.2	About the controller	6		
B.3	Scope of supply	6	6. Protective functions	26
B.4	Disposal and pollutants	6	6.1	Seizing protection 26
B.5	Hydraulic variants	7	6.2	Frost protection 26
			6.3	System protection 27
C.1	Wall installation	8	6.4	Collector protection 27
C.2	Electrical connection	9	6.5	Col.- Alarm 27
C.3	Installing the temperature sensors	11	6.6	Recooling 28
			6.7	Anti-Legionella 28
D	Terminal connection diagrams	12	7. Special functions	29
			7.1	Program selections 29
E.1	Display and Input	16	7.2	Time and Date 29
E.2	Parametrisation	17	7.3	Sensor calibration 29
E.3	Free commissioning	17	7.4	Commissioning 30
E.4	Menu sequence and menu structure	18	7.5	Factory settings 30
			7.6	Expansions 30
1. Measurement values		19	7.7	Heat quantity 30
			7.7.1	Heat metering 30
2. Statistics		20	7.7.2	AF type 31
2.1	Operating hours	20	7.7.3	Glycol portion 31
2.2	Average temperature difference ΔT	20	7.7.4	Flow rate 31
2.3	Heat output	20	7.7.4	ΔT Offset 31
2.4	Graphic overview	20	7.8	Start help function 31
2.5	Error log	20		
2.6	Reset / clear	20	8. Menu lock	32
3. Display mode		21	9. Service values	33
3.1	Schematic	21		
3.2	Overview	21	10. Language	34
3.3	Alternating	21	Z.1	Malfunctions 35
			Z.2	Replacing the fuse 36
4. Operating modes		22	Z.3.	Maintenance 36
4.1	Automatic	22		
4.2	Manual	22		
4.3	Off	22		

Safety instructions

A.1 EC declaration of conformity

By affixing the CE mark to the unit the manufacturer declares that the Temperature-Difference-Controller STDC, herein after referred to as STDC, conforms to the following relevant safety regulations:

- EC low voltage directive
73/23/EEC, as amended by 93/68/EEC
- EC electromagnetic compatibility directive
89/336/EEC version 92/31/EEC version 93/68/EEC

Conformity has been verified and the corresponding documentation and the EC declaration of conformity are kept on file by the manufacturer.

A.2 General instructions **It is essential that you read this!**

These installation and operating instructions contain basic instructions and important information regarding safety, installation, commissioning, maintenance and the optimal use of the unit. Therefore these instructions must be read completely and understood by the installation technician/specialist and by the system user before installation, commissioning and operation of the unit.

The valid accident prevention regulations, the regulations of the local power utility, the applicable standards and the installation and operating instruction of the additional system components must also be observed. The controller does not under any circumstances replace any safety devices to be provided by the customer!

Installation, electrical connection, commissioning and maintenance of the unit may only be carried out by specialists who possess the appropriate training.

For the user: Make sure that the specialist gives you detailed information on the function and operation of the controller. Always keep these instructions in the vicinity of the controller.

A.3 Explanation of symbols



Failure to observe these instructions can result in danger to life from electric voltage.



Failure to observe these instructions can result in serious damage to health such as scalding, or even life-threatening injuries.



Failure to observe these instructions can result in destruction of the unit or the system, or damage to the environment.



Information which is especially important for the function and optimal use of the unit and the system.

Safety instructions

A.4 Changes to the unit



Changes to the unit can compromise the safety and function of the unit or the entire system.

- Changes, additions to or conversion of the unit are not permitted without the written permission from the manufacturer
- It is likewise forbidden to install additional components that have not been tested together with the unit
- If it becomes clear that safe operation of the unit is no longer possible, for example because of damage to the housing, then turn the controller off immediately
- Any parts of the unit or accessories that are not in perfect condition must be exchanged immediately
- Use only original spare parts and accessories from the manufacturer.
- Markings made on the unit at the factory must not be altered, removed or made illegible
- Only the settings actually described in these instructions may be made on the controller

A.5 Warranty and liability

The controller has been manufactured and tested with regard to high quality and safety requirements. The unit is subject to the statutory guarantee period of two years from the date of sale.

The warranty and liability shall not include, however, any injury to persons or material damage that is attributable to one or more of the following causes:

- Failure to observe these installation and operating instructions
- Improper installation, commissioning, maintenance and operation
- Improperly executed repairs
- Unauthorised structural changes to the unit
- Installation of additional components that have not been tested together with the unit
- Any damage resulting from continued use of the unit despite an obvious defect
- Failure to use original spare parts and accessories
- Use of the device for other than its intended purpose
- Operation above or below the limit values listed in the specifications
- Force majeure

Description of controller

B.1 Specifications

Electrical specifications:

Mains voltage	230VAC +/- 10%
Mains frequency	50...60Hz
Power consumption	~ 1.5VA
Switched power	
- mechanic relay output	460VA for AC1 / 185W for AC3
Internal fuse	2A slow blow 250V
Protection category	IP40
Protection class	II
Sensor inputs	3 x Pt1000
Measuring range	-40°C - 300°C

Permissible ambient conditions::

Ambient temperature	
- for controller operation	0°C...40°C
- for transport/storage	0°C...60°C
Air humidity	
- for controller operation	max. 85% rel. humidity at 25°C
- for transport/storage	no moisture condensation permitted

Other specifications and dimensions

Housing design	2-part, ABS plastic
Installation methods	Wall installation
Overall dimensions	115mm x 86mm x 45mm
Aperture installation dimensions	108mm x 82mm x 25.2mm
Display	Fully graphical display, 128 x 64 dots
Operation	4 entry keys

Temperature sensors:

Collector or boiler sensor	(may not be included in the scope of supply) Pt1000, immersion sensor TT/S2 up to 180°C
Storage tank sensor	Pt1000, immersion sensor TT/S2 up to 180°C
Pipe-mounted sensor	Pt1000, pipe-mounted sensor TR/S1.5 up to 180°C
Sensor leads	2x0.75mm ² extendable up to 30m max.

Temperature resistance table for Pt1000 sensors

°C	0	10	20	30	40	50	60	70	80	90	100
Ω	1000	1039	1077	1116	1155	1194	1232	1270	1308	1347	1385

Description of controller

B.2 About the controller

The Temperature Difference Controller STDC facilitates efficient use and function control of your solar or heating system. The device is impressive most of all for its functionality and simple, almost self-explanatory operation. For each step in the input process the individual entry keys are assigned to appropriate functions and explained. The controller menu contains headwords for the measured values and settings, as well as help texts or clearly-structured graphics.

The STDC can be used as a temperature difference controller for the various system variants illustrated and explained under B.5.

Important characteristics of the STDC:

- Depiction of graphics and texts in a lighted display
- Simple viewing of the current measurement values
- Analysis and monitoring of the system by means of statistical graphics, etc.
- Extensive setting menus with explanations
- Menu block can be activated to prevent unintentional setting changes
- Resetting to previously selected values or factory settings

B.3 Scope of supply

- Temperature Difference Controller STDC
- 2 Screws 3,5x35mm, 2 plugs S6 for wall installation
- 4 strain relief clips with 8 screws, replacement fuse 2A slow blow
- 1 connection clamp for PE terminal block.
- Installation and operating instructions STDC

Optionally contained depending on design/order:

- 2-3 Pt1000 temperature sensors and immersion sleeves

Additionally available:

- Pt1000 Temperaturfühler, Tauchhülsen, Überspannungsschutz.

B.4 Disposal and pollutants

The unit conforms to the European RoHS directive 2002/95/EC for the restriction of the use of certain hazardous substances in electrical and electronic equipment.



The unit must not under any circumstances be disposed of with ordinary household refuse. Dispose of the unit only at appropriate collection points or ship it back to the seller or manufacturer.

Description of controller

B.5 Hydraulic variants



The following illustrations should be viewed only as schematic diagrams showing the respective hydraulic systems, and do not claim to be complete. The controller does not replace safety devices under any circumstances. Depending on the specific application, additional system components and safety components may be mandatory, such as check valves, non-return valves, safety temperature limiters, scalding protectors, etc., and must therefore be provided.

①

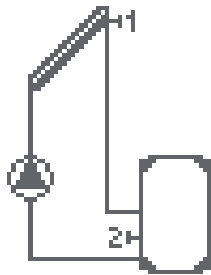

Solar with storage tank

②

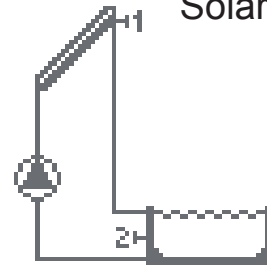

Solar with Pool

③

Solid fuel boiler with storage

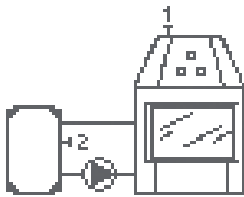

④

Storage transfer

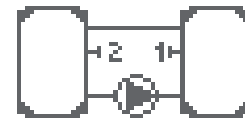

⑤

Raising of heat circuit

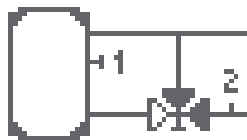

⑥

Thermostat

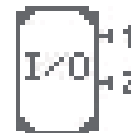

⑦

ΔT Universal



⑧

Stop valve

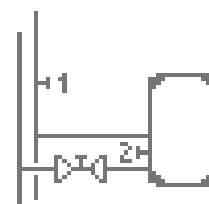

Installation

C.1 Wall installation



Caution

Install the controller only in dry areas and under the ambient conditions described under 2.1 “Specifications”. Carry out the following steps 1-8.

C.1.1

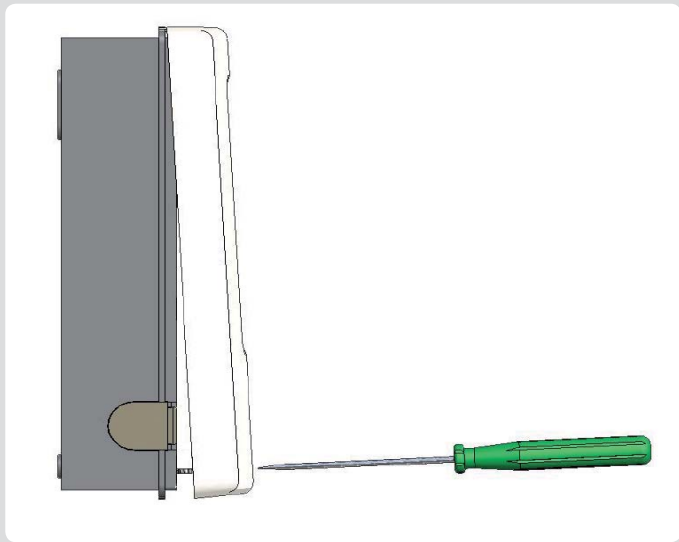

1. Unscrew cover screw completely

2. Carefully pull upper part of housing from lower part.

3. Set upper part of housing aside, being sure not to touch the electronics when doing so.

4. Hold the lower part of the housing (C.1.2) up to the selected position and mark the 2 mounting holes. Make sure that the wall surface is as even as possible so that the housing does not become distorted when it is screwed on.

C.1.2

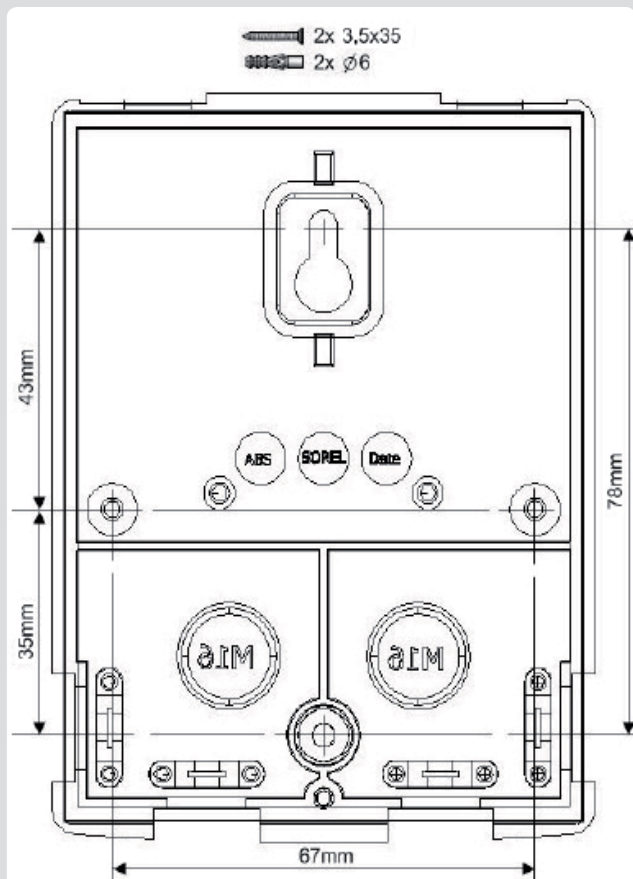

5. Using a drill and size 6 bit, drill 2 holes at the points marked on the wall and push in the plugs. Also possible is the installation with 4 drill holes.

6. Insert the upper screw and screw it in slightly.

7. Fit the upper part of the housing and insert the other screws.

8. Align the housing and tighten the screws.

Installation

C.2 Electrical connection



Before working on the unit, switch off the power supply and secure it against being switched on again! Check for the absence of power! Electrical connections may only be made by a specialist and in compliance with the applicable regulations. Do not use the controller if the housing shows visible damage.



Low-voltage cables such as temperature sensor cables must be routed separately from mains voltage cables. Feed temperature sensor cables only into the left-hand side of the unit, and mains voltage cables only into the right-hand side.



The customer must provide an all-pole disconnecting device, e.g. a heating emergency switch.



The cables being connected to the unit must not be stripped by more than 55mm, and the cable jacket must reach into the housing just to the other side of the strain relief.



We recommend the use of flexible cables to ease the installation in the clamp room.

C.2.1



1. Select necessary program/ hydraulics (see section D)

2. Strip cables by 65mm max., insert, fit the strain relief devices, strip the last 10-11 mm of the wires. (Fig. C.2.1)

C.2.1.a

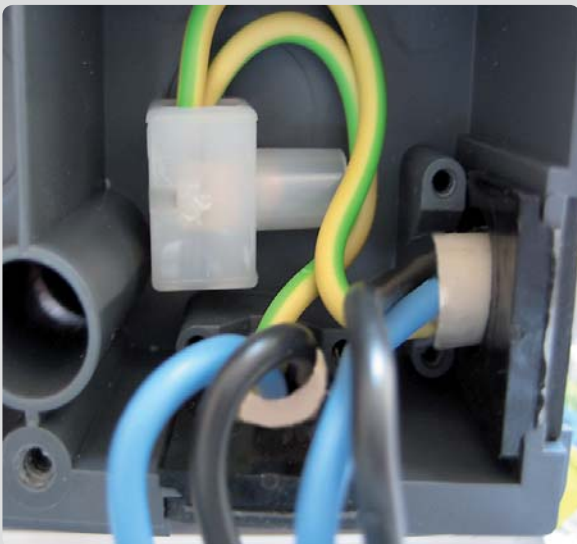

3. Open controller as described under Fig. C.1.1), insert cables and install strain reliefs

4. Install PE terminal block (see Fig. C.2.1.a).



The PE terminal block has to lie flat to prevent accidental operation of the clamps when closing the casing.

continued on
next page

Installation

C.2.1.b



5. Hold the casings as seen in Fig.C.2.1.b
6. Push clamps e.g. with thumb (Fig. C.2.1.b) or appropriate screwdriver (Fig. C.2.1.d) and connect cables according to terminal connection diagrams in section D.
7. Hinge the upper part of the casing on the top of the lower part, push the cables into the clamp room and close the casing gently.(Fig. C.2.1.c und C.2.1.e)
Important:
Pay attention to the position of the cables to prevent the accidental operation of the clamps
(Fig. C.2.1.a, C.2.1.c and C.2.1.e).

8. Fasten with screw.

9. Switch on mains voltage and place controller in operation.

C.2.1.c

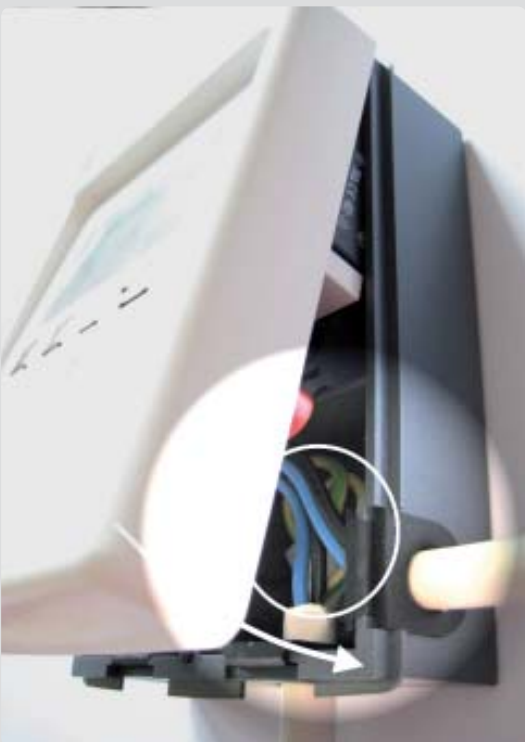

C.2.1.d



Installation

C.2.1.e

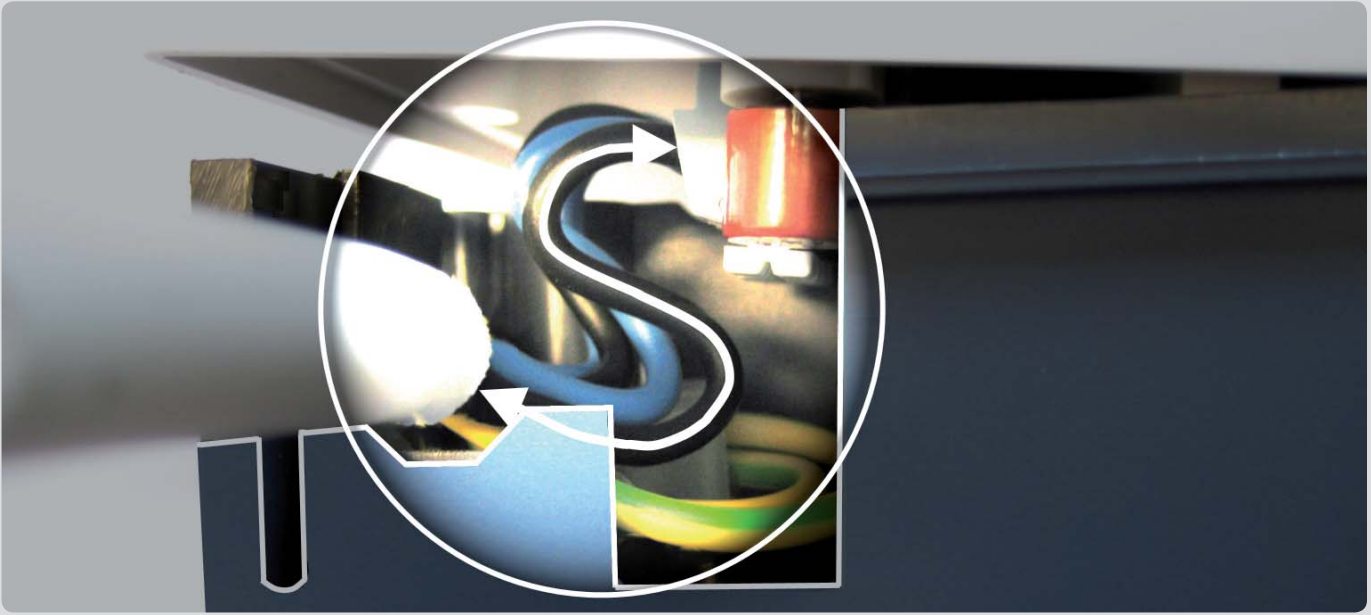

Caution

Pay attention to the position of the cables to prevent the accidental operation of the clamps (Fig. C.2.1.e sideview)

C.3 Installing the temperature sensors

The controller operates with Pt1000 temperature sensors which are accurate to the degree, thus ensuring optimal control of system functions.



Caution

If desired the sensor cables can be extended to a maximum of 30m using a cable with a cross-section of at least 0.75mm². Make sure that there is no contact resistance!

Position the sensor precisely in the area to be measured!

Only use immersion, pipe-mounted or flat-mounted sensor suitable for the specific area of application with the appropriate permissible temperature range.



Caution

The temperature sensor cables must be routed separately from mains voltage cables, and must not, for example, be routed in the same cable duct!

Installation

D Terminal connection diagrams

D.1 Solar with storage tank

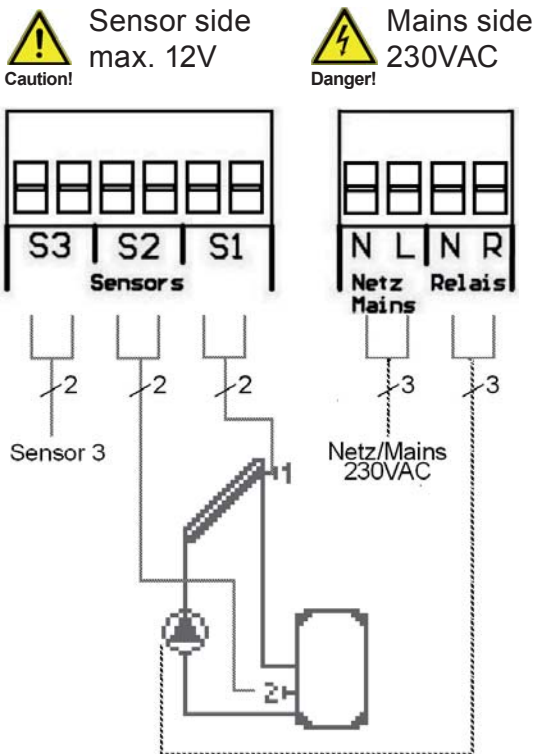

Low voltage max. 12VAC/DC connection in the left-hand terminal compartment!

Terminal: Connection for:
 S1 (2x) Sensor 1 kollektor
 S2 (2x) Sensor 2 Storage
 S3 (2x) Sensor 3 (optional)

The polarity of the sensors is freely selectable.

Mains voltages 230VAC 50-60Hz

Connection in the right-hand terminal compartment!

Terminal: Connection for:
 L Mains phase conductor L
 N Mains neutral conductor N
 R Pump phase conductor L
 N Pump neutral conductor N

The PE protective conductor must be connected to the PE metal terminal block!

D.2 Solar with swimming pool

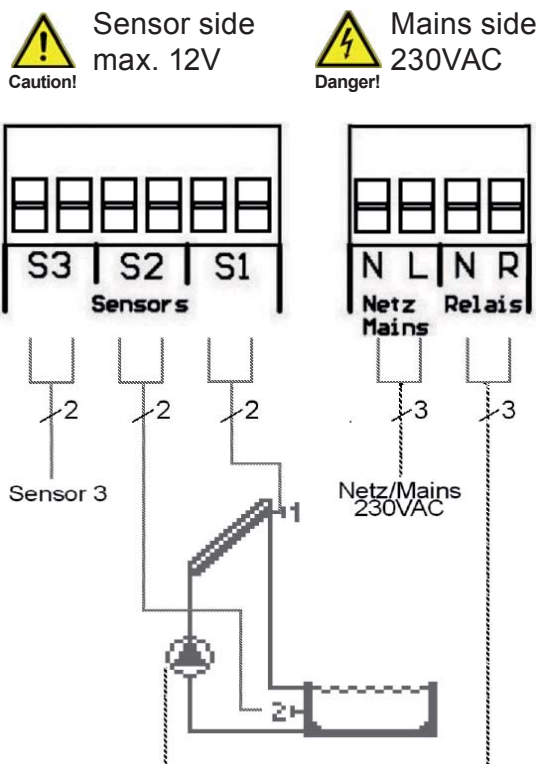

Low voltage max. 12VAC/DC connection in the left-hand terminal compartment!

Terminal: Connection for:
 S1 (2x) Sensor 1 kollektor
 S2 (2x) Sensor 2 pool
 S3 (2x) Sensor 3 (optional)

The polarity of the sensors is freely selectable.

Mains voltages 230VAC 50-60Hz

Connection in the right-hand terminal compartment!

Terminal: Connection for:
 L Mains phase conductor L
 N Mains neutral conductor N
 R Pump phase conductor L
 N Pump neutral conductor N

The PE protective conductor must be connected to the PE metal terminal block!

Installation

D.3 Solid fuel with storage tank

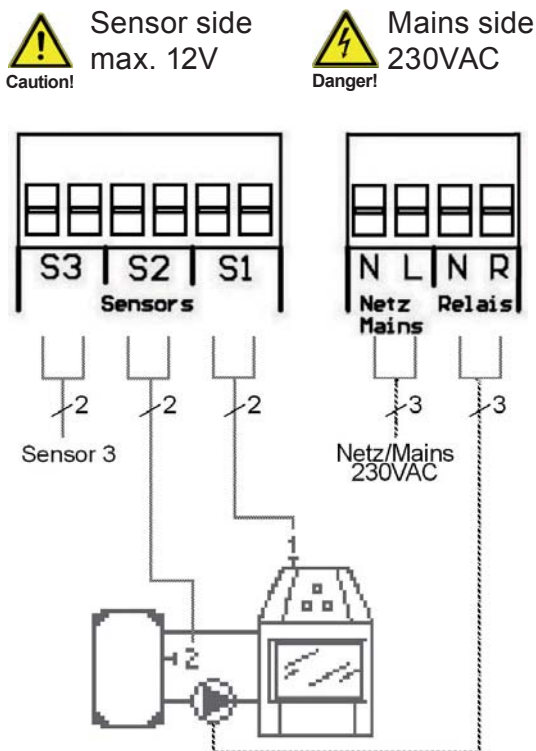

Low voltage max. 12VAC/DC connection in the left-hand terminal compartment!

Terminal: Connection for:
 S1 (2x) Sensor 1 Solid fuel boiler
 S2 (2x) Sensor 2 Storage
 S3 (2x) Sensor 3 (optional)
 The polarity of the sensors is freely selectable.

Mains voltages 230VAC 50-60Hz
 Connection in the right-hand terminal compartment!

Terminal: Connection for:
 L Mains phase conductor L
 N Mains neutral conductor N
 R Pump phase conductor L
 N Pump neutral conductor N
 The PE protective conductor must be connected to the PE metal terminal block!

D.4 Raising of heat circuit

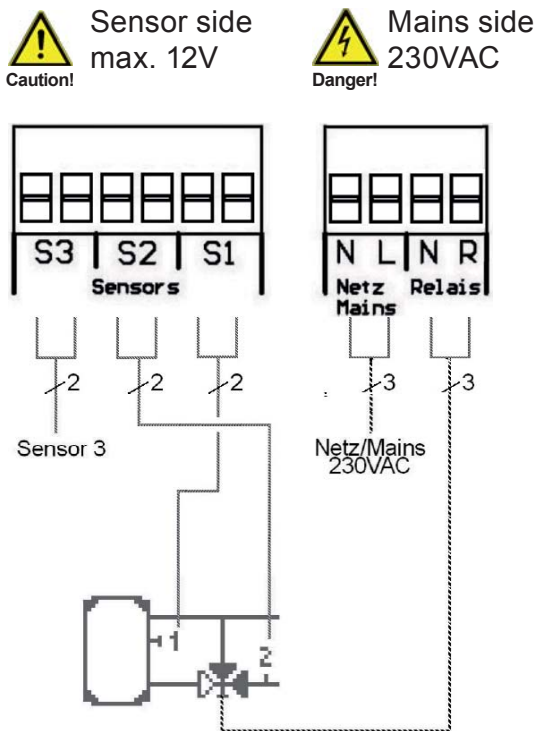

Low voltage max. 12VAC/DC connection in the left-hand terminal compartment!

Terminal: Connection for:
 S1 (2x) Sensor 1 storage
 S2 (2x) Sensor 2 backward flow
 S3 (2x) Sensor 3 (optional)
 The polarity of the sensors is freely selectable.

Mains voltages 230VAC 50-60Hz
 Connection in the right-hand terminal compartment!

Terminal: Connection for:
 L Mains phase conductor L
 N Mains neutral conductor N
 R Pump phase conductor L
 N Pump neutral conductor N
 The PE protective conductor must be connected to the PE metal terminal block!

Caution! Actuating direction of valve:
 R1 on/valve on = direction through the storage tank

Installation

D.5 Storage transfer

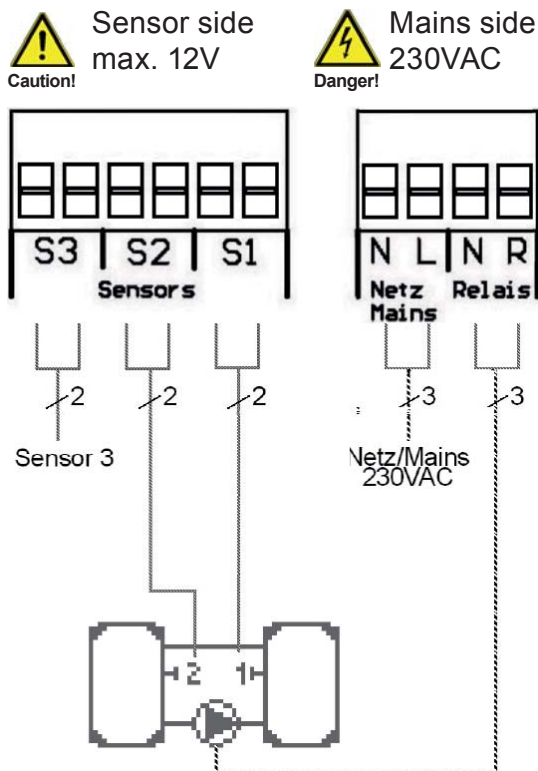

The heat is transferred from storage 1 to storage 2

Caution

Low voltage max. 12VAC/DC connection in the left-hand terminal compartment!

Terminal: Connection for:

S1 (2x) Sensor 1 storage

S2 (2x) Sensor 2 storage

S3 (2x) Sensor 3 (optional)

The polarity of the sensors is freely selectable.

Mains voltages 230VAC 50-60Hz

Connection in the right-hand terminal compartment!

Terminal: Connection for:

L Mains phase conductor L

N Mains neutral conductor N

R Pump phase conductor L

N Pump neutral conductor N

The PE protective conductor must be connected to the PE metal terminal block!

D.6 Thermostat

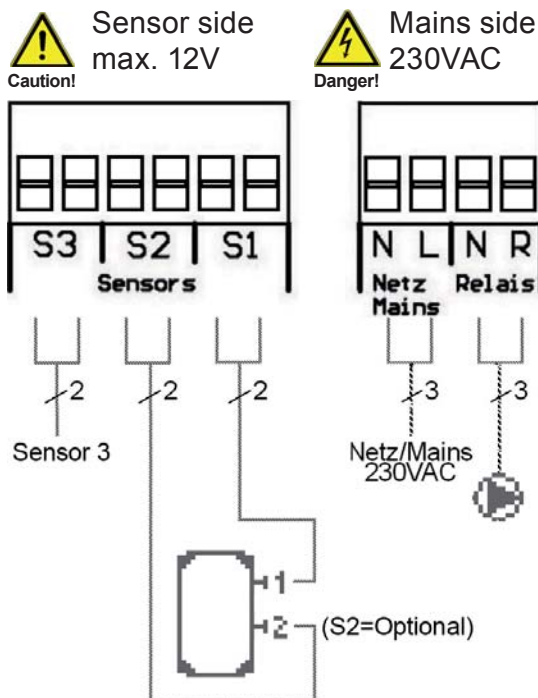

When S2 is installed = S1 is switch on sensor and S2 switch off sensor.

Caution

Low voltage max. 12VAC/DC connection in the left-hand terminal compartment!

Terminal: Connection for:

S1 (2x) Sensor 1 storage

S2 (2x) Sensor 2 (optional)

S3 (2x) Sensor 3 (optional)

The polarity of the sensors is freely selectable.

Mains voltages 230VAC 50-60Hz

Connection in the right-hand terminal compartment!

Terminal: Connection for:

L Mains phase conductor L

N Mains neutral conductor N

R Pump phase conductor L

N Pump neutral conductor N

The PE protective conductor must be connected to the PE metal terminal block!

Installation

D.7 Universal ΔT controller

Caution! Sensor side max. 12V
Danger! Mains side 230VAC

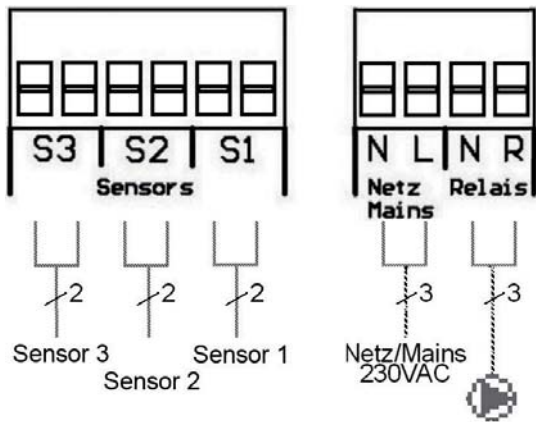

Brief description of switching function: The ΔT function sensor 1 > sensor 2 switches the pump to relay R.

Low voltage max. 12VAC/DC connection in the left-hand terminal compartment!

Terminal: Connection for:
 S1 (2x) Sensor 1 control
 S2 (2x) Sensor 2 reference
 S3 (2x) Sensor 3 (optional)

The polarity of the sensors is freely selectable.

Mains voltages 230VAC 50-60Hz

Connection in the right-hand terminal compartment!

Terminal: Connection for:
 L Mains phase conductor L
 N Mains neutral conductor N
 R Pump phase conductor L
 N Pump neutral conductor N

The PE protective conductor must be connected to the PE metal terminal block!

D.6 Stop valve

Caution! Sensor side max. 12V
Danger! Mains side 230VAC

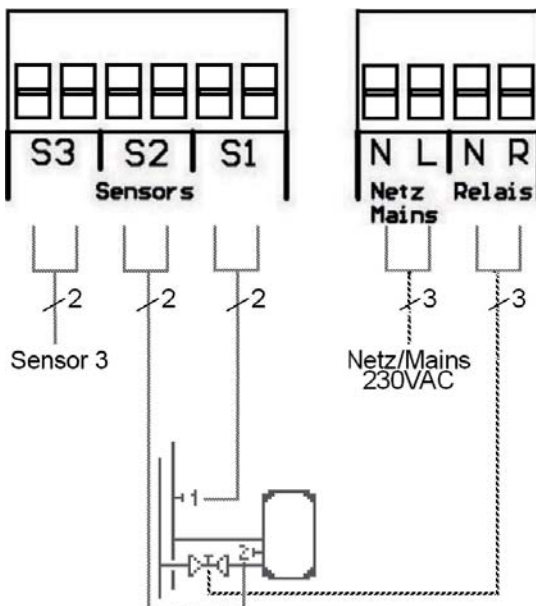

Low voltage max. 12VAC/DC connection in the left-hand terminal compartment!

Terminal: Connection for:
 S1 (2x) Sensor 1 flow
 S2 (2x) Sensor 2 storage
 S3 (2x) Sensor 3 (optional)

The polarity of the sensors is freely selectable.

Mains voltages 230VAC 50-60Hz

Connection in the right-hand terminal compartment!

Terminal: Connection for:
 L Mains phase conductor L
 N Mains neutral conductor N
 R stop valve phase conductor L
 N stop valve neutral conductor N

The PE protective conductor must be connected to the PE metal terminal block!

Operation

E.1 Display and Input

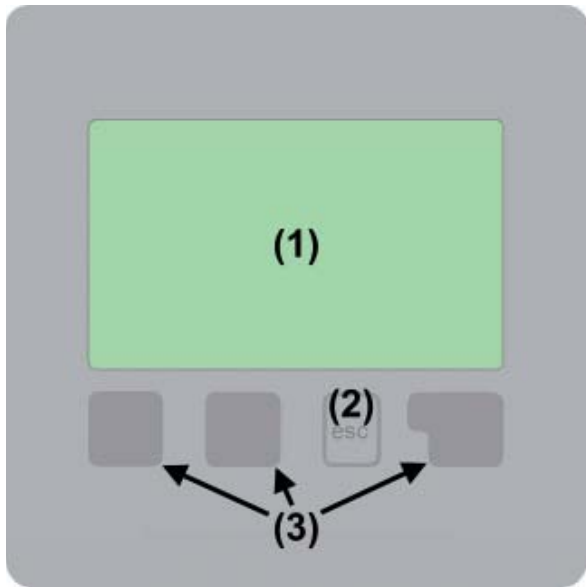

The display (1), with its extensive text and graphics mode, is almost self-explanatory, allowing easy operation of the controller.

Entries are made using four keys (2+3), which are assigned to different functions depending on the situation. The “esc” key (3) is used to cancel an entry or to exit a menu.

If applicable there will be a request for confirmation as to whether the changes which have been made should be saved.

Display symbols:

	Pump (rotates in operation)
	Valve (direction of flow black)
	Collector
	Storage tank
	Solid fuel boiler
	Swimming pool
	Temperature sensor
	Thermostat On / Off
	Warning / error message
	New information available

The function of each of the other three keys (3) is shown in the display line directly above the keys; the right-hand key generally has a confirmation and selection function.

Examples of key functions:

+/- = enlarge/shrink values

▼/▲ = scroll menu down/up

yes/no = approve/reject

Info = additional information

Back = to previous screen

ok = confirm selection

Confirm = confirm setting

Operation

E.2 Parametrisation



The first time the controller is turned on and after the language and time are set, a query appears as to whether you want to parametrise the controller using the commissioning help or not. The commissioning help can also be terminated or called up again at any time in the special functions menu. The commissioning help guides you through the necessary basic settings in the correct order, and provides

brief descriptions of each parameter in the display. Pressing the “esc” key takes you back to the previous value so you can look at the selected setting again or adjust it if desired. Pressing the “esc” more than once takes you back step by step to the selection mode, thus cancelling the commissioning help. Finally, under operating mode menu 4.2 “Manual” should be used to test the switch outputs with the consumers connected, and to check the sensor values for plausibility. Then switch on automatic mode.



Caution

Observe the explanations for the the individual parameters on the following pages, and check whether further settings are necessary for your application.

E.3 Free commissioning

If you decide not to use the commissioning help, you should make the necessary settings in the following sequence:

- Menu 10. Language
- Menu 7.2 Time and date
- Menu 7.1 Program selection
- Menu 5. Settings, all values
- Menu 6. Protective functions if adaptations are necessary
- Menu 7. Special functions if additional changes are necessary

Finally, menu 4.2 under operating mode “Manual” should be used to test the switch outputs with the consumers connected, and to check the sensor values for plausibility. Then switch on automatic mode.



Caution

Observe the explanations for the the individual parameters on the following pages, and check whether further settings are necessary for your application.

Operation

E.4 Menu sequence and menu structure

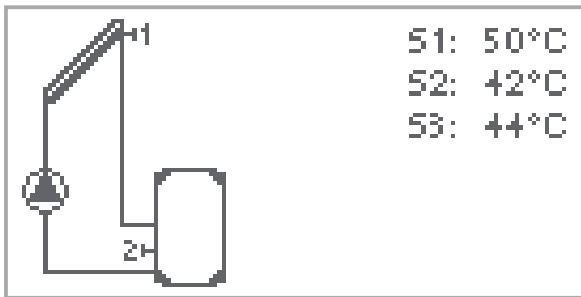

1. Measurements

2. Statistics

3. Display mode

4. Messwerte

5. Settings

6. Protections

7. Special functions

8. Menu lock

9. Service values

10. Language

The graphics or overview mode appears when no key has been pressed for 2 minutes, or when the main menu is exited by pressing "esc".

Pressing a key in graphics or overview mode takes you directly to the main menu. The following menu items are then available for selection there:

Current temperature values with explanations

Function control of the system with operating hours, etc.

Select graphics mode or overview mode

Automatic mode, manual mode or switch unit off

Set parameters needed for normal operation

Solar and frost protection, recooling, anti-seizing protection

Program selection, sensor calibration, clock, additional sensor, etc.

Against unintentional setting changes at critical points

For diagnosis in the event of an error

Select the menu language

Measurement values

1. Measurement values



The menu “1. Measurement values” serves to display the currently measured temperatures.

The menu is closed by pressing “esc” or selecting “Exit measurements”.

Selecting “Details” leads to a brief help text explaining the measurement values.

Selecting “Overview” or “esc” exits the Info mode.

If “Error” appears on the display instead of the measurement value, then there may be a defective or incorrect temperature sensor.



Caution

If the cables are too long or the sensors are not placed optimally, the result may be small deviations in the measurement values. In this case the display values can be compensated for by making entries on the controller. Follow the instructions under 7.3.

What measurement values are displayed depends on the selected program, the connected sensors and the specific device design.

Statistics

2. Statistics



The menu “2. Statistics” is used for function control and long-term monitoring of the system.

The menu is closed by pressing “esc” or selecting “Exit statistics”.



Caution

For analysis of the system data it is essential for the time to be set accurately on the controller. Please note that the clock does not continue to run if the mains voltage is interrupted, and must therefore be reset. Improper operation or an incorrect time may result in data being deleted, recorded incorrectly or overwritten. The manufacturer accepts no liability for the recorded data!

2.1 Operating hours

Display of operating hours of the solar pump connected to the controller; various time ranges (day-year) are available.

2.2 Average temperature difference ΔT

Display of the average temperature difference between the reference sensors of the solar system with the consumer switched on.

2.3 Heat output

Display of the heat output of the system. This menu can only be selected, however, when the function “Heat quantity” is activated under 7.7.

2.4 Graphic overview

This provides a clearly-organised display of the data listed under 2.1 - 2.3 as a bar graph. Various time ranges are available for comparison. The two left-hand keys can be used to page through the data.

2.5 Error log

Display of the last 20 errors occurring in the system with indication of date and time.

2.6 Reset / clear

Resetting and deleting the individual analyses. The function “All statistics” clears all analyses but not the error messages.

Display mode

3. Display mode

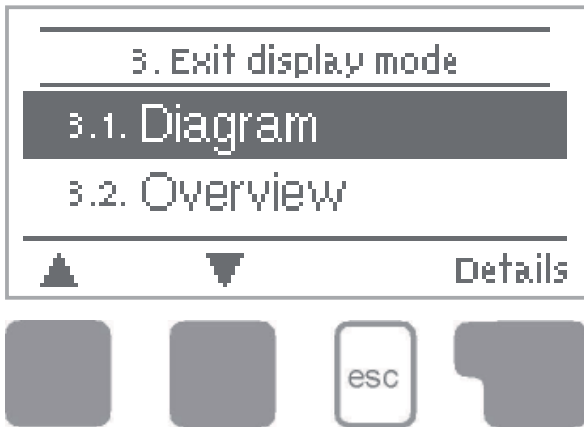

Menu “3. Display mode” is used to define the controller’s display for normal operation. This display appears whenever two minutes go by without any key being pressed. The main menu appears again when a key is pressed. The menu is closed by pressing “esc” or selecting “Exit display mode”.

3.1 Schematic

In graphics mode, the selected hydraulic systems are depicted with the measured temperatures and operating states of the connected consumers.

3.2 Overview

In overview mode, the measured temperatures and operating states of the connected consumers are depicted in text form.

3.3 Alternating

In alternating mode the schematic mode and then the overview mode are active for 5 seconds at a time.

Operating modes

4. Operating modes



In menu “4. Operating modes” the controller can either be placed in automatic mode, switched off, or placed in a manual operating mode.

The menu is closed by pressing “esc” or selecting “Exit operating modes”.

4.1 Automatic

Automatic mode is the normal operating mode of the controller. Only automatic mode provides proper controller function taking into account the current temperatures and the parameters that have been set! After an interruption of the mains voltage the controller automatically returns to the last operating mode selected!

4.2 Manual

The relay and thus the connected consumer are switched on and off by pressing a key, with no regard to the current temperatures and the parameters which have been set. The measured temperatures are also shown to provide an overview and function control.



When operating mode “Manual” is activated, the current temperatures and the selected parameters are no longer considered. There is a danger of scalding or serious damage to the system. The operating mode “Manual” may only be used by specialists for brief function tests or during commissioning!

4.3 Off



When the operating mode “Off” is activated, all controller functions are switched off. This can lead, for example, to overheating on the solar collector or other system components. The measured temperatures continue to be shown to provide an overview.

Settings

5. Settings

5. Exit adjustments	
5.1. Tmin S1	20°C
5.2. Tmax S2	60°C
 	Details



The necessary basic settings required for the control function are made in menu “5. Settings”.



Caution

This does not under any circumstances replace the safety facilities to be provided by the customer!

The menu is closed by pressing “esc” or selecting “Exit settings”.

5.1 Tmin S1

Enable/start temperature at sensor 1

If this value is exceeded at sensor 1 and the other conditions are also met, then the controller switches the pump and/or valve on. If the temperature at sensor 1 drops below this value by 5°C, then the pump and/or valve is switched off again.

Setting range: from 0°C to 99°C / default setting: 20°C



Caution

When using application 3 with solid fuel boiler, at least 60°C should be set. Consider instructions of boiler manufacturer!

5.2 Tmax S2

Switch-off temperature at sensor 2

If this value is exceeded at sensor 2 and the other conditions are also met, then the controller switches the pump and/or valve off. If sensor 2 falls below this value again and the other conditions are also met, then the controller switches the pump and/or valve on again.

Setting range: from 0°C to 99°C / default setting: 60°C



Danger

Temperature values which are set too high can lead to scalding or damage to the system. Scalding protection must be provided by the customer!

Settings

5.3 ΔT

Switching condition: Temperature difference for relay R:

If the temperature difference ΔT between the reference sensors is exceeded and the other conditions are also met, then the controller switches the pump/valve on. If the temperature difference between the reference sensors drops to ΔT_{off} , then the pump/valve is switched off again.

Settings range: ΔT 3°C to 20°C / ΔT_{off} 2°C to 19°C

Default: ΔT 10°C / ΔT_{off} 3°C.



Caution

If the set temperature difference is too small, this may result in ineffective operation or frequent clocking (switch-on and switch-off) of the pump.



Caution

The following settings only apply when hydraulic variant 6 (thermostat) is selected.

5.4 Tref

Reference temperature at sensor 1

Heating = 1. value smaller than the 2. value

If the temperature drops below Tref On (1. value) at sensor 1 and the thermostat function is enabled, (see 5.5), the relay for additional heating is switched on till the temperature reaches Tref Off (2. value).

Cooling = 1. value higher than the 2. value

If the temperature exceeds Tref On (1. value) at sensor 1 and the thermostat function is enabled (see 5.5), the relay for cooling is switched on till the temperature drops below Tref Off (2. value).

Settings range:

Tref On: 10°C - 90°C / Default: 50°C

Tref Off: 0°C - 99°C / Default: 60°C



Caution

When sensor S2 is installed, S1 is used as lead for switch on and S2 as switch off.

Settings

5.5 Thermostat times

Set the desired periods of time when the thermostat should be active. 2 periods can be set per day, settings can also be copied to other days. Outside the set times the thermostat is switched off.

Setting range: from 00:00 to 23:59 /default setting: 06:00 to 22:00

5.6 Party Funktion



With the party function the storage temperature is heated up once to the reference temperature (TrefS1), disregarding the set thermostat times.

The party mode is enabled by pressing the „esc“-key for 3 seconds in the main menu. While this mode is active, the system heats up to the reference “Tref Off”, unattached to preset thermostat times. The mode is ended once the required temperature is reached.

Protective functions

6. Protective functions



Menu "6. Protective functions" can be used to activate and set various protective functions.



Caution

This does not under any circumstances replace the safety facilities to be provided by the customer!

The menu is closed by pressing "esc" or selecting "Exit settings".

6.1 Seizing protection

If the Seizing protection is activated, then the controller switches the associated pump and/or valve on every day at 12:00 or on Sundays at 12:00 for 5 seconds in order to prevent the pump and/or valve from sticking after an extended stationary period.

Setting range: daily, weekly, off / default value: daily

6.2 Frost protection (solar only)

A two-stage frost protection function can be activated. In stage 1 the controller switches the pump on for 1 minute every hour if the collector temperature drops below the set value "Frost stage 1".

If the collector temperature drops further to the set value "Frost stage 2" the controller switches the pump on continuously. If the collector temperature then exceeds the value "Frost stage 2" by 2°C, the pump switches off again.

Frost protection setting range: on, off / default setting: off

Frost stage 1 setting range: from -25°C to 10°C or off / default setting: 7°C

Frost stage 2 setting range: from -25°C to 8°C / default setting: 5°C



Caution

This function causes energy to be lost via the collector! It is normally not activated for solar systems with antifreeze. Observe the operating instructions for the other system components!

Protective functions

6.3 System protection (solar only) priority protection

System protection prevents overheating of system components by automatic shutdown of the solar pump. If “AS Ton” is exceeded at the collector, the pump is switched off. The pump is activated again when the temperature drops below “AS TOff”.

Automatic shutdown - settings range: On / Off / Default: on

AS Ton - settings range: 60 °C to 150 °C / Default: 120 °C

AS Toff - settings range: 50 °C to Ton minus 5 °C / Default: 110 °C



When system protection is on, the temperature in the idle collector will be very high, thus the pressure in the system will rise and can damage your system. Pay close attention to the instructions of the system manufacturer.

6.4 Collector protection (solar only)

Collector protection prevents overheating of the collector. The pump is switched on to transfer heat from the collector to the storage tank.

If “CP Ton” is exceeded at the collector sensor, the pump is switched on until the temperature reaches “CP Toff” or the temperature “CP Tmax storage” is exceeded in the storage or pool.

Collector protection settings range: on / off / Voreinstellung: off

CP Ton settings range: 60°C to 150°C / Default: 110°C

CP Toff settings range: 50°C to Ton minus 10°C / Default: 100°C

CP Tmax storagesettings range: 0°C to 140°C / Default: 90°C



When collector protection is active, the storage or pool is heated well beyond Tmax S2 (see 5.2) which can result in scalding and system damage.

6.5 Col.- Alarm (solar only)

If this temperature is exceeded at the collector sensor when the solar pump is on a warning or error message is triggered. A warning message is shown in the display.

Collector alarm settings range: on / off / Default: off

Col. alarm - setting range: 60 °C to 300 °C / Default: 150 °C

Protective functions

6.6 Recooling (solar only)

In hydraulic systems with solar when the recooling function is activated excess energy from the storage tank is fed back into the collector. This only takes place if the temperature in the storage tank is higher than the value “Recool Tsetpoint” and the collector is at least 20°C cooler than the storage tank and before the storage tank temperature has dropped below the value “Recool Tsetpoint”.

Recooling settings range: on / off / Default: off

Recooling Tset settings range: 0°C to 99°C / Default: 70°C



Caution

This function causes energy to be lost via the collector! The recooling should only be activated in exceptional cases.

6.7 Anti-Legionella

With the “AL function” activated the TDC1 makes it possible to heat the storage tank up once at certain intervals (“AL interval”) to a higher temperature (“AL Tsetpoint S2”), assuming that the energy source allows this.

AL Function settings range: on / off / Default: off

AL Tset S2 settings range: 60°C to 99°C / Default: 70°C

AL interval settings range: 1 to 28 days / Default: 7 days



Caution

The anti-Legionella function is switched off at delivery. This function is only relevant for storage tanks where sensor 2 is installed. Whenever heating-up has been carried out with the anti-Legionella function is switched on, an information message with the date is shown in the display.



Danger

During the anti-Legionella function the storage tank is heated up over the set value “Tmax S2”, which can lead to scalding and damage to the system.



Caution

This anti-Legionella function does not provide complete protection against Legionella, because the controller is dependent on sufficient energy being fed in, and it is not possible to monitor the temperatures in the entire range of the storage tanks and the connected piping system. To provide complete protection against Legionella bacteria, it must be ensured that the temperature is raised to the necessary temperature, and at the same time there must be water circulation in the storage tank and piping system by means of other additional energy sources and control units.

Special functions

7. Special functions



Menu “7. Special functions” is used to set basic items and expanded functions.



Other than the time all settings may only be made by a specialist.

The menu is closed by pressing “esc” or selecting “Exit special functions”.

7.1 Program selections

The suitable hydraulic variant for the specific application is selected and set here (see section D: Hydraulic variants). The associated diagram can be displayed by pressing “info”.

Setting range: 1-5 / default value: 1



Caution

Normally the program selection is made only once during initial commissioning by the specialist. Incorrect program selection can lead to unpredictable errors.

7.2 Time and Date

This menu is used to set the current time and date.



Caution

For analysis of the system data it is essential for the time to be set accurately on the controller. Please note that the clock does not continue to run if the mains voltage is interrupted, and must therefore be reset.

7.3 Sensor calibration

Deviations in the temperature values displayed, for example due to cables which are too long or sensors which are not positioned optimally, can be compensated for manually here. The settings can be made for each individual sensor in steps of 0.5°C.

Offset S1...S3 per setting range: -10°C...+10°C Default: 0°C



Caution

Settings are only necessary in special cases at the time of initial commissioning by the specialist. Incorrect measurement values can lead to unpredictable errors.

Special functions

7.4 Commissioning

Starting the commissioning help guides you in the correct order through the basic settings necessary for commissioning, and provides brief descriptions of each parameter in the display. Pressing the “esc” key takes you back to the previous value so you can look at the selected setting again or adjust it if desired. Pressing the “esc” more than once takes you back to the selection mode, thus cancelling the commissioning help.



May only be started by a specialist during commissioning! Observe the explanations for the the individual parameters in these instructions, and check whether further settings are necessary for your application.

7.5 Factory settings

All of the settings that have been made can be reset, thus returning the controller to its delivery state.



The entire parametrisation, analyses, etc. of the controller will be lost irrevocably. The controller must then be commissioned once again.

7.6 Expansions

This menu can only be selected and used if additional options or expansions have been built into the controller. The associated supplementary installation, mounting and operation instructions are then included with the specific expansion.

7.7 Heat quantity

A simple heat metering function for basic system control can be activated in this menu. Additional settings regarding the glycol, the percentage of glycol and the flow rate of the system are required. A correction value for the heat metering is also possible by adjusting the “Offset ΔT ”



Keep in mind that the system is not changed, adjustments made in this menu are only used to calculate the heat volume and should be based on the actual system. Resulting data is only approximate value for function control!

7.7.1 Heat metering

Activate or deactivate the heat metering function

Settings range: On/off /default setting: Off

Special functions

7.7.2 AF type

Adjust the type of glycol that has been used in the system.

Settings range: Ethylene/Propylene /default setting: Ethylene

7.7.3 Glycol portion

Adjust the percentage of glycol that has been used in the system.

Settings range: 0-60% /default setting: 40%

7.7.4 Flow rate

Adjust the flow rate according to the system.

Settings range: 10-5000 l/h /default setting: 500 l/h

7.7.4 ΔT Offset

Since the calculation of the heat metering is based on the temperature of the collector and storage where measuring takes place, a possible deviation from the flow and return temperature can be compensated with this value.

Example: Displayed collector temp. 40° C, measured flow temp. 39° C, displayed storage temp. 30° C, measured return temp. 31° C means a setting of -20% (Displayed ΔT 10K, actual ΔT 8K => -20% correction value)

Settings range: -50% to +50% /default settings: 0%



Caution

Resulting data is only approximate value for function control!

7.8 Start help function (solar only)

With some solar systems, especially with vacuum tube collectors, it may occur that the measurement value acquisition at the collector sensor occurs too slowly or too inaccurately because the sensor is often not at the hottest location. When the start help is activated the following sequence is carried out:

If the temperature at the collector sensor increases by the value specified under "Increase" within one minute, then the solar pump is switched on for the set "Purging time" so that the medium to be measured can be moved to the collector sensor. If this still does not result in a normal switch-on condition, then the start help function is subject to a 5-minute lockout time.

Start help setting range: on, off/default setting: off

Purging time setting range: 2 ... 30 sec./default setting: 5 sec.

Increase setting range: 1°C....10°C/default setting: 3°C/min.



Caution

This function should only be activated by a specialist if problems arise with acquisition of measurement values. In particular follow the instructions from the collector manufacturer.

Menu lock

8. Menu lock



Menu "8. Menu lock" can be used to secure the controller against unintentional changing of the set values.

The menu is closed by pressing "esc" or selecting "Exit menu lock".

The menus listed below remain completely accessible despite the menu block being activated, and can be used to make adjustments if necessary:

1. Measurement values
2. Analysis
3. Display mode
- 7.2. Time&date
8. Menu lock
9. Service values

To lock the other menus, select "Menu lock on".
To enable the menus again, select "Menu lock off".
Setting range: on, off/default setting: off

Service values

9. Service values

9.2. Collector	50°C
9.3. Storage 1	42°C
9.4. Storage 2	44°C



The menu “9. Service values” can be used for remote diagnosis by a specialist or the manufacturer in the event of an error, etc.



Caution

Enter the values at the time when the error occurs e.g. in the table.

The menu can be closed at any time by pressing “esc”.

9.1.	
9.2.	
9.3.	
9.4.	
9.5.	
9.6.	
9.7.	
9.8.	
9.9.	
9.10.	
9.11.	
9.12.	
9.13.	
9.14.	
9.15.	
9.16.	
9.17.	
9.18.	
9.19.	
9.20.	
9.21.	
9.22.	
9.23.	
9.24.	
9.25.	
9.26.	
9.27.	
9.28.	
9.29.	
9.30.	

9.31.	
9.32.	
9.33.	
9.34.	
9.35.	
9.36.	
9.37.	
9.38.	
9.39.	
9.40.	
9.41.	
9.42.	
9.43.	
9.44.	
9.45.	
9.46.	
9.47.	
9.48.	
9.49.	
9.50.	
9.51.	
9.52.	
9.53.	
9.54.	
9.55.	
9.56.	
9.57.	
9.58.	
9.59.	
9.60.	

Language

10. Language



Menu “10. Language” can be used to select the language for the menu guidance. This is queried automatically during initial commissioning. The choice of languages may differ, however, depending on the device design. Language selection is not available in every device design!



Malfunctions

Z.1 Malfunctions with error messages

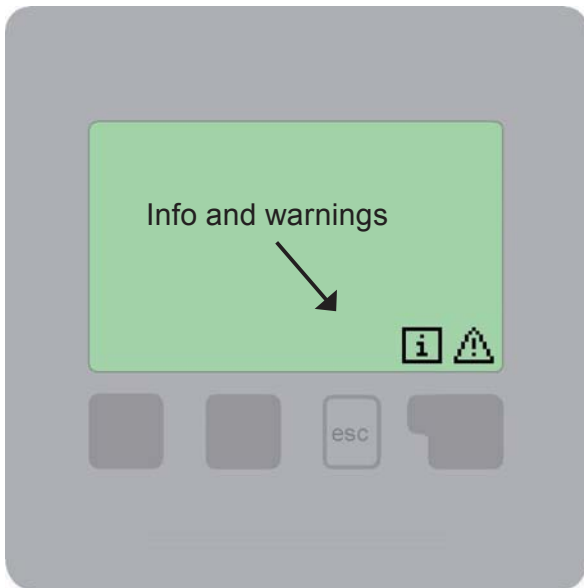

If the controller detects a malfunction, the red light flashes and the warning symbol also appears in the display. If the error is no longer present, the warning symbol changes to an info symbol and the red light no longer flashes. To obtain more detailed information on the error, press the key under the warning or info symbol.



Do not try to deal with this yourself. Consult a specialist in the event of an error!

Error messages:

Notes for the specialist:

- | | |
|--------------------------|---|
| Sensor x defective-----> | Either the sensor, the sensor input at the controller or the connecting cable is/was defective.
(Resistance table on page 5) |
| Collector alarm -----> | The collector has fallen/fell below the temperature set under menu 6.3.1. |
| Night circulation -----> | The solar pump is/was in operation between 23:00 and 04:00. (Exception see 6.6) |
| Restart-----> | The controller was restarted, for example due to a power failure. Check the date&time! |
| Time&date-----> | Is shown after a mains failure because the time&date have to be checked, and reset if necessary. |

Malfunctions

Z.2 Replacing the fuse



Repairs and maintenance may only be performed by a specialist. Before working on the unit, switch off the power supply and secure it against being switched on again! Check for the absence of power!



Only use the supplied spare fuse or a fuse of the same design with the following specifications: T2A 250V

Z.2.1

Fuse



If the mains voltage is switched on and the controller still does not function or display anything, then the internal device fuse may be defective. In that case, open the device as described under 3.1, remove the old fuse and check it. Exchange the defective fuse for a new one, locate the external source of the error (e.g. pump) and exchange it. Then first recommission the controller and check the function of the switch outputs in manual mode as described under 4.2.

Z.3. Maintenance



Caution

In the course of the general annual maintenance of your heating system you should also have the functions of the controller checked by a specialist and have the settings optimised if necessary.

Performing maintenance:

- Check the date and time (see 7.2)
- Assess/check plausibility of analyses (see 2.4)
- Check the error memory (see 2.5)
- Verify/check plausibility of the current measurement values (see 1.)
- Check the switch outputs/consumers in manual mode (see 4.2)
- Poss. optimise the parameter settings

Hydraulic variant set:

Commissioned on:

Commissioned by:

Notes:

Final declaration:

Although these instructions have been created with the greatest possible care, the possibility of incorrect or incomplete information cannot be excluded. Subject as a basic principle to errors and technical changes.

Manufacturer:

SOREL GmbH Mikroelektronik

Jahnstr. 36

D - 45549 Sprockhövel

Tel. +49 (0)2339 6024

Fax +49 (0)2339 6025

www.sorel.de info@sorel.de

Your specialist dealer: