

Heat metering controller WMC1

Installation and operating instructions



Read carefully before installation, commissioning and operation

contents

Chapter	page	chapter	page
1 Safety Instructions		9 Special functions Menu 7	
1.1 EG conformity	3	9.2 Date & Time	17
1.2 General instructions	3	9.3 Sensor calibration	17
1.3 Explanation of symbols	3	9.4 Commissioning	17
1.4 Changes	4	9.5 Factory settings	18
1.5 Warranty	4	9.6 Expansions	18
2 Description of controller		10 Menu lock Menu 5	18
2.1 Specifications	5	11 Service data Menu 6	19
2.2 About the controller	6	12 Languages	20
2.3 Scope of supply	6	13 Malfunctions/maintenance	
2.4 Disposal of pollutants	6	13.1 Error messages	21
3 Installation		13.2 Replacing the fuse	22
3.1 Wall installation	7	13.3 Maintenance	22
3.2 Electrical connection	8-9	14 Useful notes	23
3.3 Installing the sensor	10		
4 Operation			
4.1 Display and input	11		
4.2 Menu sequence	12		
5 Parametrisation			
5.1 Commissioning help	13		
5.2 Free commissioning	13		
6 Measurement	14		
Values		Menu 1	
7 Analysis		Menu 2	
7.1 Operating hours	15		
7.2 Average ΔT	15		
7.3 Heat output	15		
7.4 Graphic overview	15		
7.5 Error messages	15		
7.6 Reset/Delete	15		
8 Settings		Menu 3	
8.1 Glycoltype	16		
8.1 Glycolpercentage	16		
8.1 VFS-Type	16		
8.1 VFS-Position	16		

1.1 EC declaration of conformity

By affixing the CE mark to the unit the manufacturer declares that the WMC1 conforms to the following relevant safety regulations:

- EC low voltage directive
73/23/EEC, as amended by 93/68/EEC
- EC electromagnetic compatibility directive
89/336/EEC version 92/31/EEC version 93/68/EEC

Conformity has been verified and the corresponding documentation and the EC declaration of conformity are kept on file by the manufacturer.

1.2 General Instructions

It is essential that you read this!

These installation and operating instructions contain basic instructions and important information regarding safety, installation, commissioning, maintenance and the optimal use of the unit. Therefore these instructions must be read completely and understood by the installation technician/ specialist and by the system user before installation, commissioning and operation of the unit.

The valid accident prevention regulations, VDE regulations, the regulations of the local power utility, the applicable DIN-EN standards and the installation and operating instruction of the additional system components must also be observed. The controller does not under any circumstances replace any safety devices to be provided by the customer!

Installation, electrical connection, commissioning and maintenance of the unit may only be carried out by specialists who possess the appropriate training.

For the user: Make sure that the specialist gives you detailed information on the function and operation of the controller. Always keep these instructions in the vicinity of the controller.

1.3 Explanation of symbols



Danger

Failure to observe these instructions can result in danger to life from electric voltage.



Danger

Failure to observe these instructions can result in serious damage to health such as scalding, or even life-threatening injuries.



Caution

Failure to observe these instructions can result in destruction of the unit or the system, or damage to the environment.



Caution

Information which is especially important for the function and optimal use of the unit and the system.

1.4 Changes to the unit



Danger Changes to the unit can compromise the safety and function of the unit or the entire system.

- Changes, additions to or conversion of the unit are not permitted without the written permission from the manufacturer
- It is likewise forbidden to install additional components that have not been tested together with the unit
- If it becomes clear that safe operation of the unit is no longer possible, for example because of damage to the housing, then turn the controller off immediately
- Any parts of the unit or accessories that are not in perfect condition must be exchanged immediately
- Use only original spare parts and accessories from the manufacturer.
- Markings made on the unit at the factory must not be altered, removed or made illegible
- Only the settings actually described in these instructions may be made on the controller

1.5 Warranty and liability

The controller has been manufactured and tested with regard to high quality and safety requirements. The unit is subject to the statutory guarantee period of two years from the date of sale.

The warranty and liability shall not include, however, any injury to persons or material damage that is attributable to one or more of the following causes:

- Failure to observe these installation and operating instructions
- Improper installation, commissioning, maintenance and operation
- Improperly executed repairs
- Unauthorised structural changes to the unit
- Installation of additional components that have not been tested together with the unit
- Any damage resulting from continued use of the unit despite an obvious defect
- Failure to use original spare parts and accessories
- Use of the device for other than its intended purpose
- Operation above or below the limit values listed in the specifications
- Force majeure

2.1 Specifications

Electrical specifications:

Mains Voltage / frequency	230VAC +/- 10% / 50...60Hz
Power consumption	2VA
internal fuse	2A slow blow 250V
Protection category	IP40
Protection class	II
Sensorinputs	3 x Pt1000, 1x Vortex Flow Sensor (VFS2)
Sensor range PT1000 inputs	-40°C to 300°C
Sensor range Vortex Flow Sensor	0°C-100°C (-25°C/120°C short-term) 2l/min - 40l/min (VFS2-40)

Permissible ambient conditions:

Ambienttemperature	
for controller operation	0°C...40°C
for transport/storage	0°C...60°C
Air humidity	
for controller operation	max. 85% rel. humidity at 25°C
for transport/storage	no moisture condensation permitted

Other specifications and dimension

Housing design	2-part, ABS plastic
Installation methods	Wall installation, optionally panel installation
Overall dimensions	163mm x 110mm x 52mm
Aperture installations	
dimensions	157mm x 106mm x 31mm
Display	fully graphical display 128 x 64 dots
Light diode	Multicolour
Operation	4 entry keys
Temperature sensors:	(may not be included in the scope of supply)
Flow sensor	Pt1000, e.g. immersion sensor TT/S2 up to 180°C
Return sensor	Pt1000, e.g. immersion sensor TT/S2 up to 180°C
Vortex Flow Sensor (VFS 2-40)	flow and temperature measurement
Sensorlines PT1000:	2x 0,72mm ² , prolongable up to 30m
Vortex Flow Sensor lines:	prolongable up to 3m

Temperature-resistance table for Pt1000 sensors

°C	0	10	20	30	40	50	60	70	80	90	100
Ω	1000	1039	1077	1116	1155	1194	1232	1270	1308	1347	1385

2.2 About the controller

The heat metering controller WMC1 facilitates easy function control of your solar- and heating system. The device is impressive most of all for its functionality and simple, almost self-explanatory operation. For each step in the input process the individual entry keys are assigned to appropriate functions and explained. The controller menu contains headwords for the measured values and settings, as well as help texts or clearly-structured graphics.

Important characteristics of the WMC1

- Depiction of graphic and text in a lighted display
- Simple viewing of the current measurement values
- Analysis and monitoring of the system means of statistical graphics etc.
- Menu block can be activated to prevent unintentional setting changes
- Resetting to previously selected values or factory settings
- A wide range of additional functions are available and/or planned:
USB Interface, Ethernet interface

2.3 Scope of supply

- Heat metering controller WMC1
- 3 screws 3,5x35mm and 3 plugs 6mm for wallmounting
- 6 strain relief clips with 12 screws, replacement fuse 2AT
- Installation and operating instruction WMC1
- Vortex Flow Sensor VFS 2-40, with 2x 3/4 inch fitting pre-assembled, and 1,2m connector cable

Optionally contained depending on design/order:

- 2-3 Pt1000 temperature sensors and immersion sleeves

Additionally available:

- Pt1000 temperature sensor, immersion sleeves, overvoltage protection
- Various additional functions by means of supplementary circuit boards

2.4 Disposal and pollutants

The unit conforms to the European RoHS directive 2002/95/EC for the restriction of the use of certain hazardous substances in electrical and electronic equipment.



Caution

The unit must not under any circumstances be disposed of with ordinary household refuse. Dispose of the unit only at appropriate collection points or ship it back to the seller or manufacturer.

3.1 Wall installation



Install the controller only in dry areas and under the ambient conditions described under 2.1 “Specifications”. Carry out the following steps 1-8.

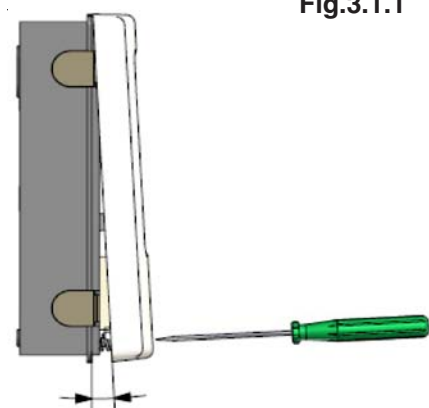
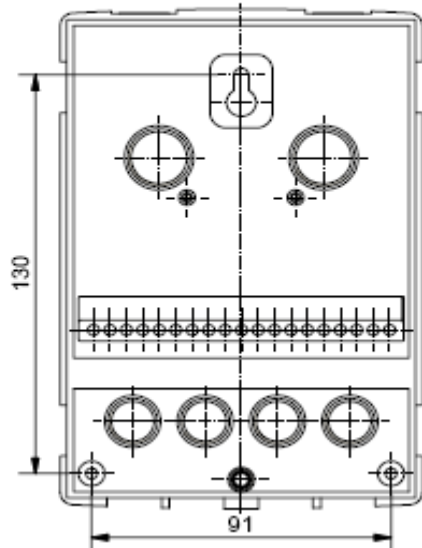
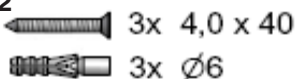

Fig.3.1.1

1. Unscrew cover screw completely
2. Carefully pull upper part of housing from lower part.
3. Set upper part of housing aside, being sure not to touch the electronics when doing so.
4. Hold the lower part of the housing up to the selected position and mark the 3 mounting holes. Make sure that the wall surface is as even as possible so that the housing does not become distorted when it is screwed on.

Fig.3.1.2



5. Using a drill and size 6 bit, drill 3 holes at the points marked on the wall and push in the plugs.
6. Insert the upper screw and screw it in slightly.
7. Fit the upper part of the housing and insert the other two screws.
8. Align the housing and tighten the three screws.

3.2 Electrical connection



Danger

Before working on the unit, switch off the power supply and secure it against being switched on again! Check for the absence of power!

Electrical connections may only be made by a specialist and in compliance with the applicable regulations.

Do not use the controller if the housing shows visible damage.



Caution

Low-voltage cables such as temperature sensor cables must be routed separately from mains voltage cables.

Feed temperature sensor cables only into the left-hand side of the unit, and mains voltage cables only into the right-hand side.



Caution

The customer must provide an all-pole disconnecting device, e.g. a heating emergency switch.



Caution

The cables being connected to the unit must not be stripped by more than 55mm, and the cable jacket must reach into the housing just to the other side of the strain relief.

Fig.3.2.1

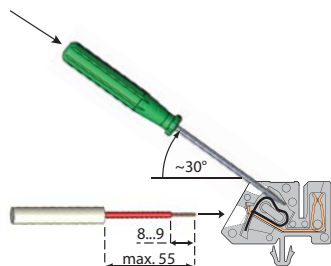
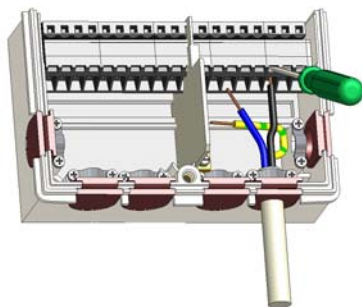

1. Select necessary program/
hydraulics (Fig. 3.2.2-3.2.16)
2. Open controller as described
under 3.1.
3. Strip cables by 55mmmax.,
insert, fit the strain relief devices,
strip the last 8-9mm of the wires.
(Fig. 3.2.1)
4. Open the terminals using a suitable
screwdriver (Fig. 3.2.1) and make
electrical connections on the
controller
5. Refit upper part of housing and fas-
ten with screw.
6. Switch on mains voltage and place
controller in operation.

3.2 Electrical connection (continued)

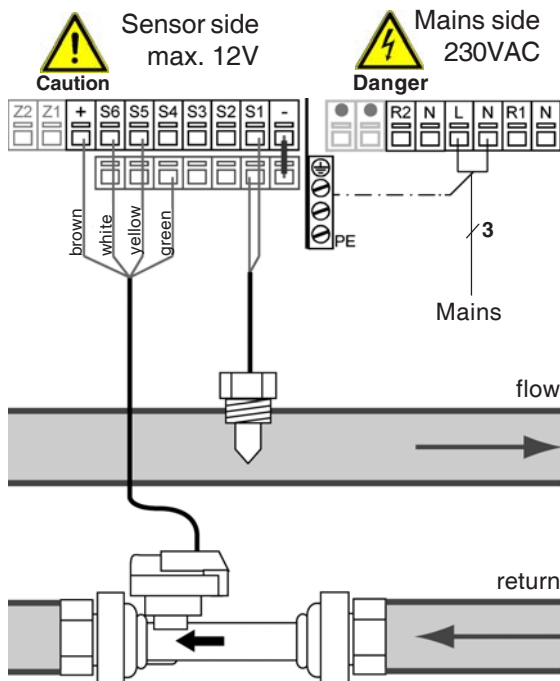

Low voltage max. 12VAC/DC
connection in the left hand terminal
compartment!

<u>Terminal:</u>	<u>Connection for:</u>
S1	Sensor 1 flow
S2,S3,S4	not used
S5	VFS Solarreturn°C (Line yellow)
S6	VFS flow rate l/min (Line white)
+	VFS +5V DC (Line brown)
-	Jumper terminal block-

Use terminal block S- for connecting
the sensor earths of (S1) and VFS (Line
green).

Polarity of S1 is freely selectable.

Mains voltage 230VAC 50-60Hz
connection in the right hand terminal
compartment!

<u>terminal:</u>	<u>connection for:</u>
L	Mains phase conductor L
N	Mains neutral conductor N
R1	-
N	-
R2	-
N	-

The PE protective conductor must be
connected to the PE metal terminal
block!

3.3 Installing the temperature sensors

The controller operates with PT1000 temperature sensors which are accurate to the degree, thus ensuring optimal control of system functions. To further ensure the precision of the heat metering, we suggest to use the flow sensor for heat metering (sensor 1) inside an immersion sleeve, so that the measuring takes place inside the fluid. Make sure that the temperature sensor cables are installed inside the insulation for about 20 cm around the measuring point to prevent cooling.



Achtung

If desired the sensor cables of the PT1000 sensors can be extended to a maximum of 30m using a cable with a cross-section of at least 0.75mm². The cables of the Vortex Flow sensors can be extended to 3 m.

Position the sensor precisely in the area to be measured!

Only use immersion, pipe-mounted or flat-mounted sensor suitable for the specific area of application with the appropriate permissible temperature range.



Caution

The Vortex Flow sensor has to be installed in the return, pay special attention to the flow direction and the maximum allowable temperature (0°C to 100°C long-term and -25°C to 120°C short-term)



Caution

The temperature sensor cables must be routed separately from mains voltage cables, and must not, for example, be routed in the same cable duct.

4.1 Display and input

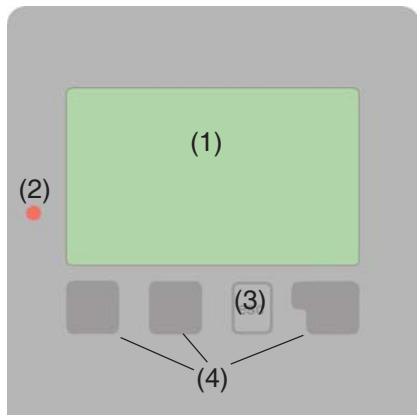

The display (1), with its extensive text and graphics mode, is almost self-explanatory, allowing easy operation of the controller.

The LED (2) lights up green when a relay is switched on.

The LED (2) lights up red when operating mode "Off" is set.

The LED (2) flashes slowly red in the operating mode "Manual".

The LED (2) flashes quickly red when an error is present.

Examples of display symbols



Warning/error message



New information available

Entries are made using four keys (3+4), which are assigned to different functions depending on the situation. The "esc" key (3) is used to cancel an entry or to exit a menu. If applicable there will be a request for confirmation as to whether the changes which have been made should be saved. The function of each of the other three keys (4) is shown in the display line directly above the keys; the right-hand key is generally has a confirmation and selection function.

Examples of key functions:

+/- = enlarge/shrink values

▼/▲ = scroll menu down/up

yes/no = approve/reject

Info = additional information

Back = to previous screen

ok = confirm selection

Confirm = confirm setting

4.2 Menu sequence and menu structure

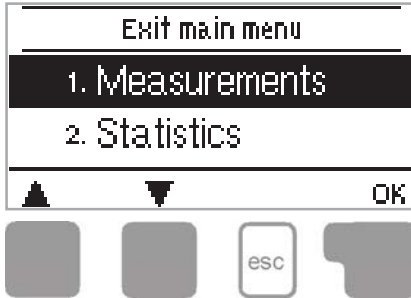

The graphics or overview mode appears when no key has been pressed for 2 minutes, or when the main menu is exited by pressing „esc“.

Pressing a key in the graphics or overview mode takes you directly to the main menu. The following menu items are then available for selection there:

1. Measurements	Current temperature values with explanation (see 6.)
2. Statistics	Function control of the system with operating hours etc. (see 7.)
3. Adjustments	Set parameters needed for system operation (see 8.)
4. Special functions	Clock, sensor calibration, additional sensors, commissioning, factory settings, etc. (see 9.)
5. Menu lock	Against unintentional setting changes at critical points (siehe 10.)
6. Service data	For diagnosis in the event of an error (see 12.)
7. Languages	Select menu language. Language selection is not available in every device design!

5.1 Commissioning help



The first time the controller is turned on and after the language and time are set, a query appears as to whether you want to parametrise the controller using the commissioning help or not. The commissioning help can also be terminated or called up again at any time in the special functions menu. The commissioning help guides you through the necessary

basic settings in the correct order, and provides brief descriptions of each parameter in the display.

Pressing the “esc” key takes you back to the previous value so you can look at the selected setting again or adjust it if desired. Pressing the “esc” more than once takes you back step by step to the selection mode, thus cancelling the commissioning help. Finally, menu 4.2 under operating mode “Manual” should be used to test the switch outputs with the consumers connected, and to check the sensor values for plausibility. Then switch on automatic mode.



Achtung

Observe the explanations for the the individual parameters on the following pages, and check whether further settings are necessary for your application.

5.2 Free commissioning

If you decide not to use the commissioning help, you should make the necessary settings in the following sequence:

- Menu 7. Language (see 11.)
- Menu 7.2 Time and date (see 9.2)
- Menu 7.1 VFS-Type (see 8.1)
- Menu 5. Adjustments, all settings (see 8.x)



Achtung

Observe the explanations for the the individual parameters on the following pages, and check whether further settings are necessary for your application.

6. Measurement values

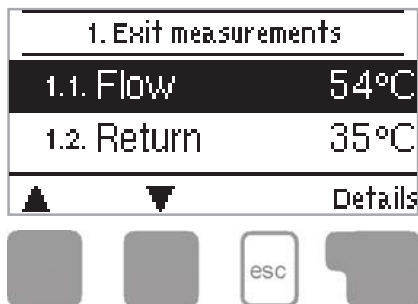

The menu “1. Measurement values” serves to display the currently measured temperatures.

The menu is closed by pressing “esc” or selecting “Exit measurement values”.

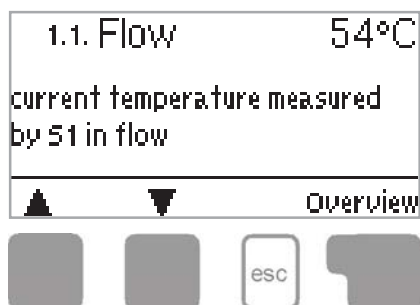

Selecting “Details” leads to a brief help text explaining the measurement values.

Selecting “Overview” or “esc” exits the Info mode.

If the cables are too long or the sensors are not placed optimally, the result may be small deviations in the measurement values. In this case the display values can be compensated for by making entries on the controller. Follow the instructions under 12.3.

What measurement values are displayed depends on the selected program, the connected sensors and the specific device design.



Achtung

If “Error” appears on the display instead of the measurement value, then there may be a defective or incorrect temperature sensor.

7. Analyses



The menu “2. Analyses” is used for function control and long-term monitoring of the system.

The submenus described under 7.1-7.6 are available.



The menu is closed by pressing “esc” or selecting “Exit analyses”.



For analysis of the system data it is essential for the time to be set accurately on the controller. Please note that the clock does not continue to run if the mains voltage is interrupted, and must therefore be reset. Improper operation or an incorrect time may result in data being deleted, recorded incorrectly or overwritten.

The manufacturer accepts no liability for the recorded data!

7.1 Operating hours Menu 2.1

Display of the operating hours of the WMC1.

7.2 Average temperature difference ΔT Menu 2.2

Display of the average temperature difference between the reference sensors with active flow.

7.3 Heat output Menu 2.3

Display of the heat output of the system.

7.4 Graphic overview Menu 2.4

This provides a clearly-organised display of the data listed under 7.1-7.3 as a bar graph. Various time ranges are available for comparison. The two left-hand keys can be used to page through the data.

7.5 Error messages Menu 2.5

Display of the last three errors occurring in the system with indication of date and time.

7.6 Reset / delete Menu 2.6

Resetting and deleting the individual analyses. The function “All statistics” clears all analyses except for the error messages.

8.1 Adjustments

3. Exit adjustments	
3.1. VFS type	40l/min
3.2. AF type	Ethylene
▲	▼
	Details

In this menu certain settings for the VFS and the anti-freeze agent can be adjusted.



VFS Type Menu 3.1

Select the used type of VFS sensor and its max flow rate.

VFS-Type Setting range: 1-20 l/min , 2-40 l/min, 5-100 l/min l/min / Default 40 l/min

AF type Menu 3.2

Select the type of anti freeze/glycol that is used in your system.

AF type - Setting range: Ethylene, Propylene / Default: Ethylene

Glycol portion Menu 3.3

Select the amount of glycol used in your system

Glycol portion - Settings range: 0...60% / Default 40%

VFS position Menu 3.4

Setting the VFS position determines the position of the sensors for the heat metering. If VFS position “flow” is selected, it is assumed that sensor 1 is installed in the “return” and vice versa.

VFS position Settings range: return, flow / Default: return



Caution

To prevent damage to the Vortex Flow sensor, it is highly recommended to install it in the return; if however the VFS is installed in the flow make sure that the max. temperatures are not exceeded! (0°C to 100°C long-term and -25°C to 120°C short-term)

9.1 Special functions

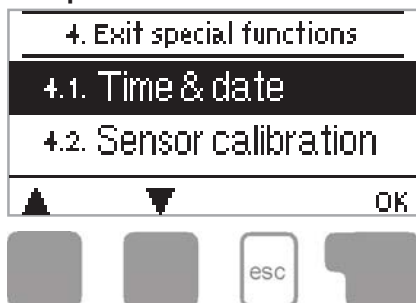

This menu is used to set basic items and expanded functions.



Caution

Other than the time all settings may only be made by a specialist.

The menu is closed by pressing “esc” or selecting “Exit special functions”

9.2 Time and date Menu 4.2

This menu is used to set the current time and date.



Achtung

For analyses of the system data it is essential for the time to be set accurately on the controller. Please note that the clock does not continue to run if the mains voltage is interrupted, and must therefore be reset.

9.3 Sensor calibration Menu 4.3 / 4.3.1 - 4.3.3

Deviations in the temperature values displayed, for example due to cables which are too long or sensors which are not positioned optimally, can be compensated for manually here. The settings can be made for each individual sensor in steps of 0.5°C.

Offset S1...S6 per setting range: -100 ... +100 default settings: 0



Achtung

Settings are only necessary in special cases at the time of initial commissioning by the specialist. Incorrect measurement values can lead to unpredictable errors.

9.4 Commissioning Menu 44.4

Starting the commissioning help guides you in the correct order through the basic settings necessary for commissioning, and provides brief descriptions of each parameter in the display.

Pressing the “esc” key takes you back to the previous value so you can look at the selected setting again or adjust it if desired. Pressing the “esc” more than once takes you back to the selection mode, thus cancelling the commissioning help. (see also 5.1)



Achtung

May only be started by a specialist during commissioning! Observe the explanations for the individual parameters in these instructions, and check whether further settings are necessary for your application.

9.5 Factory settings Menu 4.5

All of the settings that have been made can be reset, thus returning the controller to its delivery state.



The entire parametrisation, analyses, etc. of the controller will be lost irrevocably. The controller must then be commissioned once again.

9.6 Expansions Menu 4.6

This menu can only be selected and used if additional options or expansions have been built into the controller.

The associated supplementary installation, mounting and operation instructions are then included with the specific expansion.

10. Menu lock



Menu “5. Menu lock” can be used to secure the controller against unintentional changing of the set values.

The menu is closed by pressing “esc” or selecting “Exit menu lock”.

The menus listed below remain completely accessible despite the menu lock being activated, and can be used to make adjustments if necessary:

1. Measurement
2. Statistics
- 4.2. Time and date
5. Menu lock
6. Service data

To lock the other menus, select “Menu lock on”.

To enable the menus again, select “Menu lock off”.

Setting range: on, off/default setting: off

11. Service data

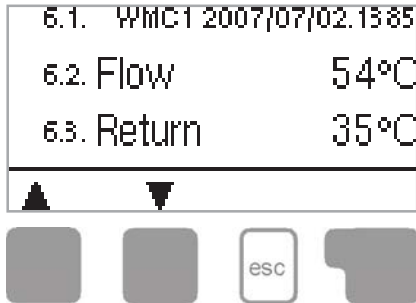

The menu “6. Service data” can be used for remote diagnosis by a specialist or the manufacturer in the event of an error, etc.



Enter the values at the time when the error occurs e.g. in **Achtung** the table.

The menu can be closed at any time by pressing “esc”.

6.1.	
6.2.	
6.3.	
6.4.	
6.5.	
6.6.	
6.7.	
6.8.	
6.6.	
6.10.	
6.11.	
6.12.	
6.13.	
6.14.	
6.15.	
6.16.	

12. Language



Menu “7. Language” can be used to select the language for the menu guidance. This is queried automatically during initial commissioning.

The choice of languages may differ, however, depending on the device design. Language selection is not available in every device design!

13.1 Malfunctions with error messages

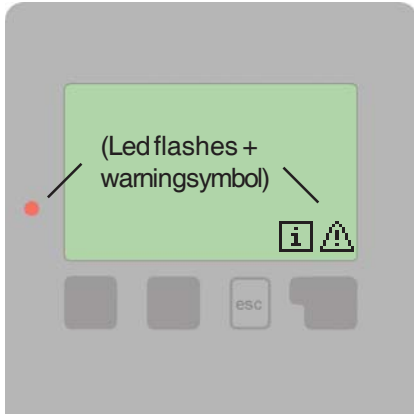

If the controller detects a malfunction, the red light flashes and the warning symbol also appears in the display. If the error is no longer present, the warning symbol changes to an info symbol and the red light no longer flashes.

To obtain more detailed information on the error, press the key under the warning or info symbol.



Danger

Do not try to deal with this yourself.

Consult a specialist in the event of an error!

Possible error/information messages:

Notes for the specialist:

Sensor x defective----->

Means that either the sensor, the sensor input at the controller or the connecting cable is/was defective. (Resistance table on page 5)

Restart----->

Means that the controller was restarted, for example due to a power failure. Check the date&time!

Time&Date----->

This display appears automatically after a mains failure because the time&date have to be checked, and reset if necessary.

13.2 Replacing the fuse



Danger

Repairs and maintenance may only be performed by a specialist. Before working on the unit, switch off the power supply and secure it against being switched on again! Check for absence of power!



Danger

Only use the supplied spare fuse or a fuse of the same design with the following specifications: T2A 250V

Fig.3.1.1

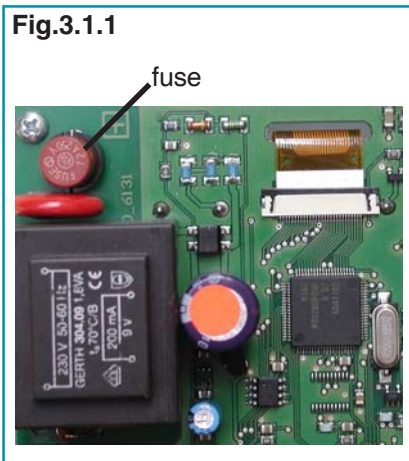

If the mains voltage is switched on and the controller still does not function or display anything, then the internal device fuse may be defective. In that case, open the device as described under 3.1, remove the old fuse and check it.

Exchange the defective fuse for a new one.

13.3. Maintenance



Achtung

In the course of the general annual maintenance of your heating system you should also have the functions of the controller checked by a specialist and have the settings optimised if necessary.

Performing maintenance:

- Check the date and time (see 9.2)
- Assess/check plausibility of statistics (see 7.1 - 7.4)
- Check the error messages (see 7.5)
- Verify/check the plausibility of the current measurement (see 6.)
- Poss. optimise the parameter settings



The **Service data** (see 11.) include not only current measurement values and operating states, but also all of the settings for the controller. Write the service values down just once after commissioning has been successfully completed.



In the event of uncertainty as to the control response or malfunctions the service values are a proven and successful method for remote diagnosis. Write the service values down (see 11.) at the time that the suspected malfunction occurs. Send the **service value table** by fax or e-mail with a brief description of the error to the specialist or manufacturer.



To protect against loss of data, record any statistics and data that are particularly important to you (see 7.) at regular intervals.



To ensure the accuracy of the heat metering we suggest to install the flow sensor in an immersion sleeve. However if this is not possible, it is recommended to compensate the possible inaccuracy of the pipe sensor with the adjustment of the „manual offset“. To do this, place the flow sensor near the return sensor and adjust the manual offset until both values are the same (see 9.3). Do not forget to place the flow sensor on the flow pipe afterwards.

Hydraulic variant set:

Commissioned on:

Commissioned by:

Notes:

Final declaration:

Although these instructions have been created with the greatest possible care, the possibility of incorrect or incomplete information cannot be excluded. Subject as a basic principle to errors and technical changes.

Manufacturer: SOREL GmbH Mikroelektronik Jahnstr. 36 D - 45549 Sprockhövel Tel. +49 (0)2339 6024 Fax +49 (0)2339 6025 www.sorel.de info@sorel.de	Your specialist dealer
--------------------------------------------------------------------------------------------------------------------------------------------------------------------	------------------------
