

# Heat pump controller WPC 5

Installation and operating instructions



Read carefully before installation, commissioning and operation

---

## Contents

Chapter	Page	Chapter	Page
<b>1 Safety instructions</b>		<b>10 Settings</b>	<b>Menu 5</b>
1.1 EC conformity	3	10.1 Su/Wi day	24
1.2 General instructions	3	10.2 Su/Wi night	24
1.3 Explanation of symbols	3	10.3 Min. flow	24
1.4 Changes	4	10.4 Slope	25
1.5 Warranty	4	10.5 Day correction	26
<b>2 Description of controller</b>		10.6 Night correction	26
2.1 Specifications	5	10.7 Comfort tempera- ture boost	26
2.2 About the controller	6	10.8 Low-rate period boost	26
2.3 Scope of supply	6	10.9 Set/Actual-	27
2.4 Disposal of pollutants	6	10.10 Set/Actual+	27
2.5 Hydraulic variants	7	10.11 HW min.	27
<b>3 Installation</b>		10.12 HW heating	27
3.1 Wall installation	8	10.13 HW heating for low- rate period	27
3.2 Electrical connection	9-12	<b>11 Protective functions</b>	<b>Menu 6</b>
3.3 Installing the sensors	13	11.1 Anti-seizing protection	28
3.4 Installing RS-485	13	11.2 Frost protection for the heat pump	28
3.5 External error condition	13	11.3 Max. heating circuit	28
<b>4 Operation</b>		11.4 Max. domestic hot water	28
4.1 Display and input	14	11.5 Anti-Legionella	28
4.2 Menu sequence	15	<b>12 Special functions</b>	<b>Menu 7</b>
<b>5 Parametrisation</b>		12.1 Program selection	30
5.1 Commissioning help	16	12.2 Heat metering	30
5.2 Free commissioning	16	12.3 Sensor calibration	30
<b>6 Measurement values</b>	<b>Menu 1</b>	12.4 Commissioning	30
6.1 Measurement values	17	12.5 Factory settings	30
<b>7 Statistics</b>	<b>Menu 2</b>	12.6 Expansions	30
7.1 Operating hours	18	12.7 Heat pump system	32
7.2 Average $\Delta T$	18	<b>13 Menu block</b>	<b>Menu 8</b>
7.3 Heat output	18	<b>14 Language</b>	<b>Menu 10</b>
7.4 Graphic overview	18	<b>15 Service values</b>	<b>Menu 9</b>
7.5 Error messages	18	<b>16 Malfunctions/mainte- nance</b>	35
7.6 Reset/clear	18	16.1 Error messages	36
<b>8 Operating times</b>	<b>Menu 3</b>	16.2 Replacing the fuse	36
8.1 Time & date	19	16.3 Maintenance	36
8.2-8.4 Heating circuit	20	<b>17 Useful notes</b>	37
8.5-8.7 Domestic hot water	21		
<b>9 Operating modes</b>	<b>Menu 4</b>		
9.1 Heating circuit	22		
9.2 Domestic hot water	22		
9.3 Manual	23		

### 1.1 EC declaration of conformity

By affixing the CE mark to the unit the manufacturer declares that the WPC5 conforms to the following relevant safety regulations:

- EC low voltage directive  
73/23/EEC, as amended by 93/68/EEC
- EC electromagnetic compatibility directive  
89/336/EEC version 92/31/EEC version 93/68/EEC

Conformity has been verified and the corresponding documentation and the EC declaration of conformity are kept on file by the manufacturer.

### 1.2 General instructions **It is essential that you read this!**

These installation and operating instructions contain basic instructions and important information regarding safety, installation, commissioning, maintenance and the optimal use of the unit. Therefore these instructions must be read completely and understood by the installation technician/specialist and by the system user before installation, commissioning and operation of the unit.

The valid accident prevention regulations, VDE regulations, the regulations of the local power utility, the applicable DIN-EN standards and the installation and operating instruction of the additional system components must also be observed. The controller does not under any circumstances replace any safety devices to be provided by the customer!

Installation, electrical connection, commissioning and maintenance of the unit may only be carried out by specialists who possess the appropriate training. For the user: Make sure that the specialist gives you detailed information on the function and operation of the controller. Always keep these instructions in the vicinity of the controller.

### 1.3 Explanation of symbols



Danger

Failure to observe these instructions can result in danger to life from electric voltage.



Danger

Failure to observe these instructions can result in serious damage to health such as scalding, or even life-threatening injuries.



Caution

Failure to observe these instructions can result in destruction of the unit or the system, or damage to the environment.



Caution

Information which is especially important for the function and optimal use of the unit and the system.

## 1.4 Changes to the unit



### Danger

Changes to the unit can compromise the safety and function of the unit or the entire system.

- Changes, additions to or conversion of the unit are not permitted without written permission from the manufacturer
- It is likewise forbidden to install additional components that have not been tested together with the unit
- If it becomes clear that safe operation of the unit is no longer possible, for example because of damage to the housing, then turn the controller off immediately
- Any parts of the unit or accessories that are not in perfect condition must be exchanged immediately
- Use only original spare parts and accessories from the manufacturer.
- Markings made on the unit at the factory must not be altered, removed or made illegible
- Only the settings actually described in these instructions may be made on the controller

## 1.5 Warranty and liability

The controller has been manufactured and tested with regard to high quality and safety requirements. The unit is subject to the statutory guarantee period of two years from the date of sale.

The warranty and liability shall not include, however, any injury to persons or material damage that is attributable to one or more of the following causes:

- Failure to observe these installation and operating instructions
- Improper installation, commissioning, maintenance and operation
- Improperly executed repairs
- Unauthorised structural changes to the unit
- Installation of additional components that have not been tested together with the unit
- Any damage resulting from continued use of the unit despite an obvious defect
- Failure to use original spare parts and accessories
- Use of the device for other than its intended purpose
- Operation above or below the limit values listed in the specifications
- Force majeure

## 2.1 Specifications

### Electrical specifications:

Mains voltage	230VAC +/- 10%
Mains frequency	50...60Hz
Power consumption	2VA
Total switched power	460VA (relay outputs 1-4)
Switched power per relay	460VA for AC1 / 185W for AC3
Internal fuse	2A slow-blow 250V
Protection category	IP40
Protection class	II
Sensor inputs	5 x Pt1000, 1 x SOREL RT21
Measuring range	-40 to 110°C

### Permissible ambient conditions:

Ambient temperature	
for controller operation	0°C...40°C
for transport/storage	0°C...60°C
Air humidity	
for controller operation	max. 85% rel. humidity at 25°C
for transport/storage	no moisture condensation permitted

### Other specifications and dimensions

Housing design	2-part, ABS plastic
Installation methods	Wall installation, optionally panel installation
Overall dimensions	163mm x 110mm x 52mm
Aperture installation dimensions	157mm x 106mm x 31mm
Display	Fully graphical display, 128 x 64 dots
Light diode	Multicolour
Operation	4 entry keys

### Temperature sensors:

	(may not be included in the scope of supply)
Immersion sensor	Pt1000, e.g. immersion sensor TT/P4 up to 95°C
Pipe-mounted sensor	Pt1000, e.g. pipe-mounted sensor TR/P4 up to 95°C
Outdoor sensor	Pt1000, e.g. outdoor sensor TA52
Remote adjuster	SOREL RT21
Sensor leads	2x0.75mm <sup>2</sup> extendable up to 30m max.

Temperature resistance table for Pt1000 sensors

°C	0	10	20	30	40	50	60	70	80	90	100
Ω	1000	1039	1077	1116	1155	1194	1232	1270	1308	1347	1385

## 2.2 About the controller

The Heat pump controller WPC 5 facilitates efficient use and function control of your heat pump and heating system. The device is impressive most of all for its functionality and simple, almost self-explanatory operation. For each step in the input process the individual entry keys are assigned to appropriate functions and explained. The controller menu contains headwords for the measured values and settings, as well as help texts or clearly-structured graphics.

The WPC 5 can be used as a heat pump controller for the various system variants illustrated and explained under 2.5.

Important characteristics of the WPC 5:

- Depiction of graphics and texts in a lighted display
- Simple viewing of the current measurement values
- Statistics and monitoring of the system by means of statistical graphics, etc.
- Extensive setting menus with explanations
- Menu block can be activated to prevent unintentional setting changes
- Detection of external error conditions and Voltage Interlock
- Resetting to previously selected values or factory settings
- A wide range of additional functions are available and/or planned:  
Network integration with expansion modules via RS485 interface

## 2.3 Scope of supply

- Heat pump controller WPC 5
- 3 screws 3.5x35mm and 3 plugs 6mm for wall installation
- 6 strain relief clips with 12 screws, replacement fuse 2A slow-blow
- Installation and operating instructions WPC 5

Optionally contained depending on design/order:

- 2-5 PT1000 temperature sensors and immersion sleeves

Additionally available:

- Pt1000 temperature sensor, immersion sleeves, overvoltage protection
- Room thermostat remote adjuster SOREL RT21
- Fastening clip for panel installation of the housing

## 2.4 Disposal and pollutants

The unit conforms to the European RoHS directive 2002/95/EC for the restriction of the use of certain hazardous substances in electrical and electronic equipment.



The unit must not under any circumstances be disposed of with ordinary household refuse. Dispose of the unit only at appropriate collection points or ship it back to the seller or manufacturer.

## 2.5 Hydraulic variants



Caution

The following illustrations should be viewed only as schematic diagrams showing the respective hydraulic systems, and do not claim to be complete. The controller does not replace safety devices under any circumstances. Depending on the specific application, additional system components and safety components may be mandatory, such as check valves, non-return valves, safety temperature limiters, scalding protectors, etc., and must therefore be provided.

①

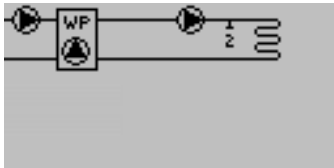

Hydraulic variant / program 1

Heat pump with heating circuit

②

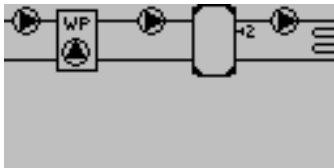

Hydraulic variant / program 2

Heat pump with buffer storage tank and heating circuit

③

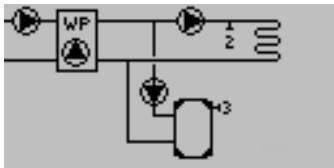

Hydraulic variant / program 3

Heat pump with domestic hot water storage tank and heating circuit

④

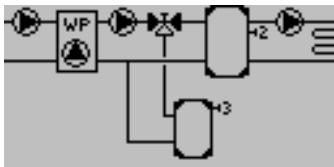

Hydraulic variant / program 4

Heat pump with domestic hot water-storage, buffer and heating circuit. (domestic hot water charging via change-over valve)

⑤

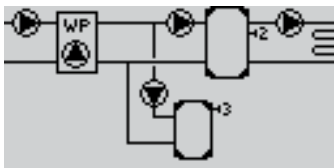

Hydraulic variant / program 5

Heat pump with domestic hot water-storage, buffer and heating circuit. (domestic hot water charging via charging pump)

### 3.1 Wall installation



Caution

Install the controller only in dry areas and under the ambient conditions described under 2.1 „Specifications“. Carry out the following steps 1-8.

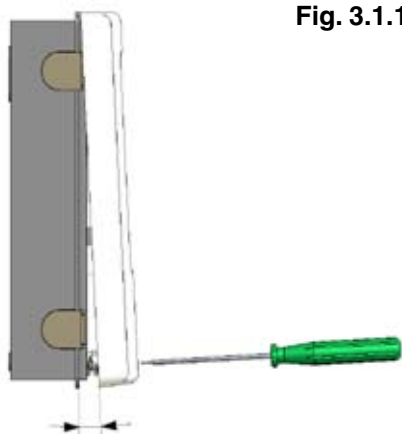
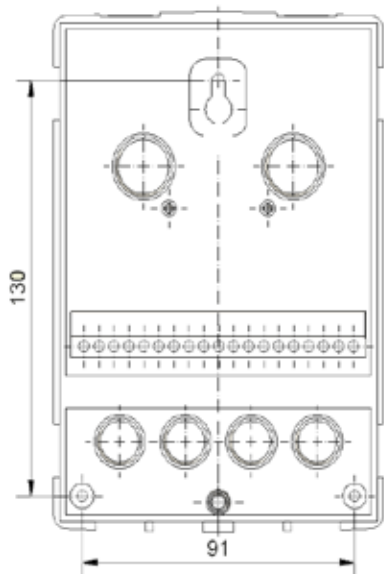

Fig. 3.1.1

1. Unscrew cover screw completely
2. Carefully pull upper part of housing from lower part.
3. Set upper part of housing aside, being sure not to touch the electronics when doing so.
4. Hold the lower part of the housing up to the selected position and mark the 3 mounting holes. Make sure that the wall surface is as even as possible so that the housing does not become distorted when it is screwed on.

Fig. 3.1.2 3x 4,0 x 40

3x Ø6



5. Using a drill and size 6 bit, drill 3 holes at the points marked on the wall and push in the plugs.
6. Insert the upper screw and screw it in slightly.
7. Fit the upper part of the housing and insert the other two screws.
8. Align the housing and tighten the three screws.



Caution

For panel installation, a special installation set is available as an accessory.

### 3.2 Electrical connection



**Danger**

Before working on the unit, switch off the power supply and secure it against being switched on again!

Check for the absence of power!

Electrical connections may only be made by a specialist and in compliance with the applicable regulations. The controller may not be put into operation if there is visible damage to the housing, e.g. cracks.



**Caution**

Low-voltage cables such as temperature sensor cables must be routed separately from mains voltage cables. Feed temperature sensor cables only into the left-hand side of the unit, and mains voltage cables only into the right-hand side.



**Caution**

The customer must provide an all-pole disconnecting device, e.g. a heating emergency switch.

Connect only 230VAC mains voltage to potential-free relay R5, never low voltage!



**Caution**

The cables being connected to the unit must not be stripped by more than 55mm, and the cable jacket must reach into the housing just to the other side of the strain relief.

**Fig. 3.2.1**

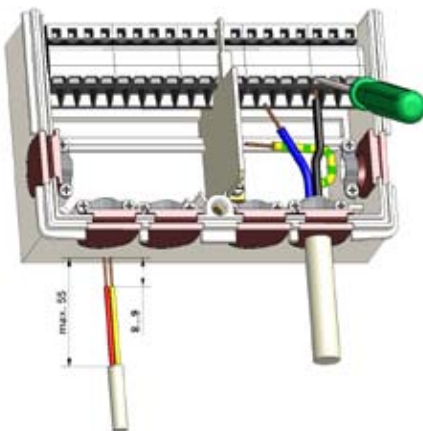

1. Select necessary program/hydraulics (see 2.5)
2. Open controller housing (see 3.1)
3. Strip cables by 55mm max., insert, fit the strain relief devices, strip the last 8-9mm of the wires (Fig.3.2.1)
4. Open the terminals using a suitable screwdriver (Fig. 3.2.1) and make electrical connections on the controller (Pages 10-12)
5. Refit upper part of housing and fasten with screw.
6. Switch on mains voltage and place controller in operation

### 3.2.2 Electrical terminals of the WPC5

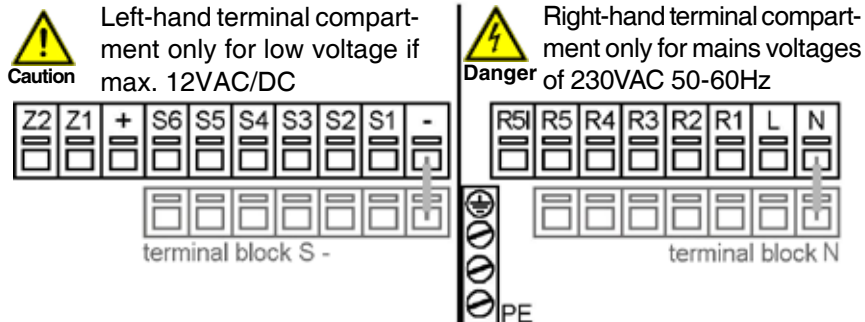

Connection on low voltage side:

- Temperature sensors terminals S1-S6 and terminal block S- (any polarity)
- Optional digital interface RS485 terminal Z1/Z2

Observe detailed connection diagrams under 3.2.3-3.2.10!

Connection on mains voltage side:

- Protective conductor to the PE metal block
- Neutral conductor to terminal block N
- Switch outputs terminals R1-R5
- Mains phase conductor terminal L (R5I)

Observe detailed connection diagrams under 3.2.3-3.2.10!

### 3.2.3 Electrical connection for hydraulics 1

„Heat pump with heating circuit“

**Low voltage** max. 12VAC/DC connection in the left-hand terminal compartment!

**Mains voltage** 230VAC 50-60Hz connection in the right-hand terminal compartment!

Terminal:	Connection for:
-	Jumper terminal block S-
S1	Sensor 1 outdoor
S2	Sensor 2 heating circuit
S3	Sensor 3 not used
S4	Sensor 4 glycol flow
S5	Sensor 5 glycol return
S6	Sensor 6 RT21
+	remains unused
Z1	Option: RS485 a
Z2	Option: RS485 b

Use terminal block S- for connecting the sensor earths of S1-S6. The polarity of the sensor is freely selectable. S6 RT21 can be connected as an option.

Terminal:	Connection for:
N	Jumper terminal block N
L	Mains phase conductor L
R1	Heating circuit pump
R2	not used
R3	not used
R4	Glycol pump
R5	Compressor
R5I	Phase conductor L for R5

Use terminal block N to connect all neutral conductors N!  
The PE protective conductor must be connected to the PE metal terminal block!

### 3.2.4 Electrical connection for hydraulics 2

„Heat pump with heating circuit buffer“

**Low voltage** max. 12VAC/DC connection in the left-hand terminal compartment!

<u>Terminal:</u>	<u>Connection for:</u>
-	Jumper terminal block S-
S1	Sensor 1 outdoor
S2	Sensor 2 heating circuit buffer
S3	Sensor 3 not used
S4	Sensor 4 glycol flow
S5	Sensor 5 glycol return
S6	Sensor 6 RT21
+	remains unused
Z1	Option: RS485 a
Z2	Option: RS485 b

Use terminal block S- for connecting the sensor earths of S1-S6. The polarity of the sensor is freely selectable. S6 RT21 can be connected as an option.

**Mains voltage** 230VAC 50-60Hz connection in the right-hand terminal compartment!

<u>Terminal:</u>	<u>Connection for:</u>
N	Jumper terminal block N
L	Mains phase conductor L
R1	Heating circuit pump
R2	not used
R3	Buffer charging pump
R4	Glycol pump
R5	Compressor
R5I	Phase conductor L for R5

Use terminal block N to connect all neutral conductors N!  
The PE protective conductor must be connected to the PE metal terminal block!

### 3.2.5 Electrical connection for hydraulics 3

„Heat pump with heating circuit+HW“

**Low voltage** max. 12VAC/DC connection in the left-hand terminal compartment!

<u>Terminal:</u>	<u>Connection for:</u>
-	Jumper terminal block S-
S1	Sensor 1 outdoor
S2	Sensor 2 heating circuit
S3	Sensor 3 domestic hot water storage tank
S4	Sensor 4 glycol flow
S5	Sensor 5 glycol return
S6	Sensor 6 RT21
+	remains unused
Z1	Option: RS485 a
Z2	Option: RS485 b

Use terminal block S- for connecting the sensor earths of S1-S6. The polarity of the sensor is freely selectable. S6 RT21 can be connected as an option.

**Mains voltage** 230VAC 50-60Hz connection in the right-hand terminal compartment!

<u>Terminal:</u>	<u>Connection for:</u>
N	Jumper terminal block N
L	Mains phase conductor L
R1	Heating circuit pump
R2	Domestic hot water pump
R3	not used
R4	Glycol pump
R5	Compressor
R5I	Phase conductor L for R5

Use terminal block N to connect all neutral conductors N!  
The PE protective conductor must be connected to the PE metal terminal block!

### 3.2.6 Electrical connection for hydraulics 4

„Heat pump with heating circuit buffer+HW(V)“

**Low voltage** max. 12VAC/DC connection in the left-hand terminal compartment!

Terminal:	Connection for:
-	Jumper terminal block S-
S1	Sensor 1 outdoor
S2	Sensor 2 heating circuit
S3	Sensor 3 domestic hot water storage tank
S4	Sensor 4 glycol flow
S5	Sensor 5 glycol return
S6	Sensor 6 RT21
+	remains unused
Z1	Option: RS485 a
Z2	Option: RS485 b

Use terminal block S- for connecting the sensor earths of S1-S6. The polarity of the sensor is freely selectable. S6 RT21 can be connected as an option.

**Mains voltage** 230VAC 50-60Hz connection in the right-hand terminal compartment!

Terminal:	Connection for:
N	Jumper terminal block N
L	Mains phase conductor L
R1	Heating circuit pump
R2	Domestic hot water valve
R3	Storage tank charging pump
R4	Glycol pump
R5	Compressor
R5I	Phase conductor L for R5

Use terminal block N to connect all neutral conductors N!  
The PE protective conductor must be connected to the PE metal terminal block!

### 3.2.7 Electrical connection for hydraulics 5

„Heat pump with heating circuit buffer+HW(P)“

**Low voltage** max. 12VAC/DC connection in the left-hand terminal compartment!

Terminal:	Connection for:
-	Jumper terminal block S-
S1	Sensor 1 outdoor
S2	Sensor 2 heating circuit
S3	Sensor 3 domestic hot water storage tank
S4	Sensor 4 glycol flow
S5	Sensor 5 glycol return
S6	Sensor 6 RT21
+	remains unused
Z1	Option: RS485 a
Z2	Option: RS485 b

Use terminal block S- for connecting the sensor earths of S1-S6. The polarity of the sensor is freely selectable. S6 RT21 can be connected as an option.

**Mains voltage** 230VAC 50-60Hz connection in the right-hand terminal compartment!

Terminal:	Connection for:
N	Jumper terminal block N
L	Mains phase conductor L
R1	Heating circuit pump
R2	Domestic hot water pump
R3	Buffer charging pump
R4	Glycol pump
R5	Compressor
R5I	Phase conductor L for R5

Use terminal block N to connect all neutral conductors N!  
The PE protective conductor must be connected to the PE metal terminal block!

### 3.3 Installing the temperature sensors

The controller operates with Pt1000 temperature sensors which are accurate to the degree, thus ensuring optimal control of system functions.



**Caution**

If desired the sensor cables can be extended to a maximum of 30m using a cable with a cross-section of at least 0.75mm<sup>2</sup>. Make sure that there is no contact resistance!

Position the sensor precisely in the area to be measured!

Only use immersion, pipe-mounted or flat-mounted sensor suitable for the specific area of application with the appropriate permissible temperature range.



**Caution**

The temperature sensor cables must be routed separately from mains voltage cables, and must not, for example, be routed in the same cable duct!

### 3.4 Installing the RS485 interface cable - optional only



**Caution**

A 2-strand twisted-pair cable must be used for the RS485 interface.

The cable must be routed separately from mains voltage cables.

The WPC5 must be equipped with a special additional circuit board for the RS485 interface; this board is available as an accessory.

The interface cable for the bus connection is then routed from the WPC5 basic unit to the specific EMC... expansion module. This connection is made on the terminals provided for this purpose; ensure proper polarity (a / b). If more than two units are to be connected, the cable must be routed from one device to another and connected in an open ring.



**Caution**

The first and the last unit in the sequence must be fitted with a jumper for the RS485 interface. Please consult the installation instructions for the expansion modules for details.

### 3.5 External error messages and Voltage interlock

The controller offers the possibility to display an external error condition via the S5 sensor input terminals. Similarly sensor input S4 can be used to interlock the heat-pump for a pre-programmed time should an external error condition arise. Both these functions are achieved by connecting the sensor inputs to voltage free normally open contacts of external relays.

A short circuit across S4 stops the heat-pump after a programmed blocking delay and keeps the heat pump locked out until a programmed lock-out time has elapsed, while a short circuit across S5 shuts down the heat pump while the short circuit is in place. The relevant error condition is displayed on the controller screen.

### 4.1 Display and input

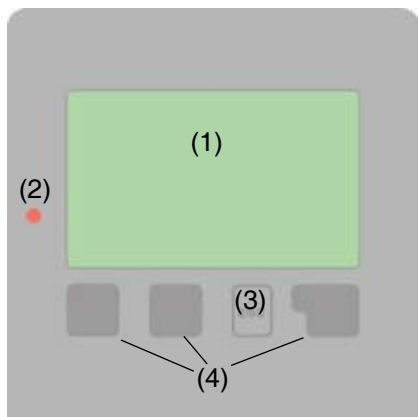

The display (1), with its extensive text and graphics mode, is almost self-explanatory, allowing easy operation of the controller.

The LED (2) lights up green when a relay is switched on.

The LED (2) lights up red when operating mode „Off“ is set.

The LED (2) flashes slowly red in the operating mode „Manual“.

The LED (2) flashes quickly red when an error is present.

Examples of display symbols:

 Pump (rotates in operation)

 Valve (direction of flow black)

 Heat pump (compressor)

 Buffer storage tank

 Domestic hot water storage tank

 Temperature sensor

 Warning / error message

 New information available

Entries are made using four keys (3+4), to which different functions are assigned depending on the situation. The „esc“ key (3) is used to cancel an entry or to exit a menu. If applicable there will be a request for confirmation as to whether the changes which have been made should be saved.

The function of each of the other three keys (4) is shown in the display line directly above the keys; the right-hand key is generally has a confirmation and selection function.

Examples of key functions:

+/- = enlarge/shrink values

▼/▲ = scroll menu down/up

yes/no = approve/reject

Info = additional information

Back = to previous screen

ok = confirm selection

Confirm = confirm setting

## 4.2 Menu sequence and menu structure

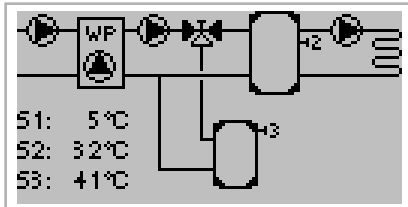

The graphics or overview mode appears when no key has been pressed for 2 minutes, or when the main menu is exited by pressing „esc“.



Pressing a key in graphics or overview mode takes you directly to the main menu. The following menu items are then available for selection there:



1. Measurements	Current temperature values with explanations (see 6.)
2. Statistics	Function control of the system with operating hours, etc. (see 7.)
3. Times	Operating times for heating circuit and hot water, setting the clock (see 8.)
4. Operation mode	Operating times for heating circuit and hot water, manual mode (see 9.)
5. Adjustments	Set parameters needed for system operation (see 10.)
6. Protections	Anti-seizing protection, Frost., Tmax, Anti-Legionella activation (see 11.)
7. Special functions	Program selection, sensor calibration, display mode, etc. (see 12.)
8. Menu lock	Against unintentional setting changes at critical points (see 13.)
9. Service data	For diagnosis in the event of an error (see 14.)

### 5.1 Commissioning help



The first time the controller is turned on and after the language and time are set, a query appears as to whether you want to parametrise the controller using the commissioning help or not. The commissioning help can also be terminated or called up again at any time in the special functions menu. The commissioning help guides you through the neces-

sary basic settings in the correct order, and provides brief descriptions of each parameter in the display.

Pressing the „esc“ key takes you back to the previous value so you can look at the selected setting again or adjust it if desired. Pressing the „esc“ more than once takes you back step by step to the selection mode, thus cancelling the commissioning help. Finally, menu 4.3 under operating mode „Manual“ should be used to test the switch outputs with the consumers connected, and to check the sensor values for plausibility. Then switch on automatic mode.



**Caution**

Observe the explanations for the the individual parameters on the following pages, and check whether further settings are necessary for your application.

### 5.2 Free commissioning

If you decide not to use the commissioning help, you should make the necessary settings in the following sequence:

- Menu 10. Language (see 14.)
- Menu 3. Define time, date and operating times (see 8.1-8.7)
- Menu 7.1 Program selection (see 12.1)
- Menu 5. Settings, all values (see 10.)
- Menu 6. Protective functions if adaptations are necessary (see 11.)
- Menu 7. Special functions if additional changes are necessary (see 12.)

Finally, menu 4.2 under operating mode „Manual“ should be used to test the switch outputs with the consumers connected, and to check the sensor values for plausibility. Then switch on automatic mode.



**Caution**

Observe the explanations for the the individual parameters on the following pages, and check whether further settings are necessary for your application.

## 6. Measurement values

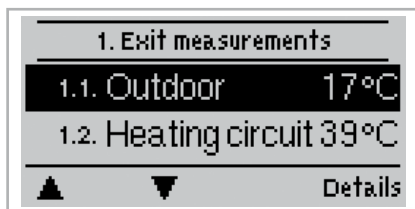

Menu “1. Measurement values” serves to display the currently measured temperatures.

The menu is closed by pressing “esc” or selecting “Exit measurement values”.



Selecting “Info” leads to a brief help text explaining the measurement values.

Selecting “Overview” or “esc” exits the Info mode.



### Caution

If “Error” appears on the display instead of the measurement value, then there may be a defective or incorrect temperature sensor.

If the cables are too long or the sensors are not placed optimally, the result may be small deviations in the measurement values. In this case the display values can be compensated for by making entries on the controller. Follow the instructions under 12.3.

What measurement values are displayed depends on the selected program, the connected sensors and the specific device design.

## 7. Statistics

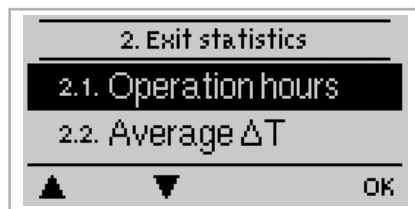

Menu “2. Statistics” is used for function control and long-term monitoring of the system.

The submenus described under 7.1-7.5 are available.

The menu is closed by pressing “esc” or selecting “Exit statistics”.



**Caution**

For system data statistics it is essential for the time to be set accurately on the controller. Please note that the clock continues to run for about 24 hours if the mains voltage is interrupted, and after that has to be reset. Improper operation or an incorrect time may result in data being cleared, recorded incorrectly or overwritten.

The manufacturer accepts no liability for the recorded data!

### 7.1 Operating hours Menu 2.1

Display of operating hours of the heat pump connected to the controller; various time ranges (day-year) are available.

### 7.2 Average $\Delta T$ Menu 2.2

Display of the average temperature difference of the last seven days. Measured between the glycol flow and the glycol return with the heat pump switched on.

### 7.3 Heat output Menu 2.3

Display of the heat quantity that the heat pump has picked up from the glycol. The displayed value is used only for function control, and never for purposes of billing or the like. This menu can be selected if the function “Heat quantity” is activated under 12.2.

### 7.4 Graphic overview Menu 2.4

This provides a clearly-organised display of the data listed under 7.1-7.3 as a bar graph. Various time ranges are available for comparison. The two left-hand keys can be used to page through the data.

### 7.5 Error messages Menu 2.5

Display off the last three errors in the system with indication of date and time.

### 7.6 Reset / clear Menu 2.6

Resetting and clearing the individual statistics. Selecting “All statistics” clears everything except for the error log.

## 8. Times

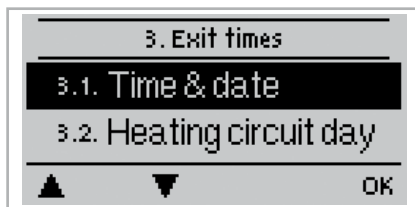

Menu “3. Times” is used to set the time, date, operating times for the heating circuit and hot water.



**Caution**

The associated temperature reference values are specified in menu 5 “Settings”!



The menu is closed by pressing “esc” or selecting “Exit display mode”.

### 8.1 Time & date Menu 3.1

This menu is used to set the current time and date.



**Caution**

For proper functioning of the controller and statistics for the system data it is essential for the time to be set accurately on the controller. Please note that the clock continues to run for about 24 hours if the mains voltage is interrupted, and after that has to be reset.

### 8.2 Heating circuit, day Menu 3.2

This menu is used to select the daytime mode times for the heating circuit; two time periods can be specified for each weekday and copied over to the following days.

*Setting range: Two time ranges for each day of the week*

*Default setting: Mon-Sun 06:00-22:00*

*Note: See 10. for the associated temperature settings*



**Caution**

Times that are not specified are automatically considered to be nighttime mode. The set times are only taken into account in the heating circuit operating mode “Automatic”

### 8.3 Heating circuit, comf. Menu 3.3

This menu can be used to select a time range for each day of the week in which the heating circuit is supplied with an increased comfort temperature, e.g. for quick heating in the morning.

*Setting range: One time range for each day of the week*

*Default setting: Mon-Sun off*

*Note: See 10. for the associated temperature settings*

## 8. Times (continued)

### 8.4 Heating for low-rate period Menu 3.4

This menu can be used to select a time range for each day of the week in which the heating circuit is supplied with an increased temperature, e.g. during low-rate periods of the power utility. Especially in systems with a buffer storage tank, the heat retained from the low-rate periods can then be retrieved via the heating circuit later, thus saving lower operating costs.

*Setting range: One time range for each day of the week*

*Default setting: Mon-Sun off*

*Note: See 10. for the associated temperature settings*



The heating circuit setting for the low-rate time period should be selected appropriately according to the specific patterns of use and the low-rate periods of the relevant power utility.

### 8.5 Domestic hot water enable Menu 3.5

This menu is used to select the enable times for the domestic hot water heating; two time periods can be specified for each weekday and copied over to the following days.

*Setting range: Two time ranges for each day of the week*

*Default setting: Mon-Sun 06:00-22:00*

*Note: See 10. for the associated temperature settings*



The controller automatically switches off the domestic hot water heating during the times that are not configured.

### 8.6 Domestic hot water for low-rate period Menu 3.6

This menu can be used to select a time range for each day of the week in which, in order to save operating costs, the domestic hot water storage tank is charged to a higher temperature, e.g. during the low-rate periods of the power utility.

*Setting range: One time range for each day of the week*

*Default setting: Mon-Sun off*

*Note: See 10. for the associated temperature settings*



The domestic hot water setting for the low-rate time period should be selected appropriately according to the specific patterns of use and the low-rate periods of the relevant power utility.

## 8. Times (continued)

### 8.7 Domestic hot water, AL Menu 3.7

This menu can be used to select a time range for each day of the week in which the domestic hot water storage tank is charged to a higher temperature, e.g. for protection against Legionella.

*Setting range: One time range for each day of the week*

*Default setting: Mon-Sun off*

*Note: See 10. for the associated temperature settings*



**Danger**

This function does not provide complete protection against Legionella, because the controller is dependent on sufficient energy being fed in, and it is not possible for the controller to monitor the temperatures in the entire range of the storage tanks and the connected piping system (see additional notes under 11.5).

## 9. Operating mode

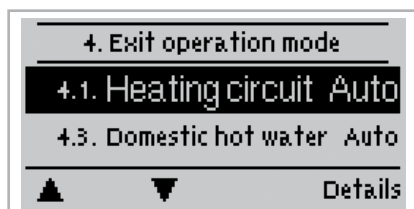

Menu “4. Operating modes” is used to specify the operating modes for the heating circuit and domestic hot water.

After an interruption of the mains voltage the controller automatically returns to the last operating mode selected!

The menu is closed by pressing “esc” or selecting “Exit operating modes”.



**Caution** The controller works with the set operating times and the corresponding different reference flow or domestic hot water temperature values only in the automatic mode.

### 9.1 Heating circuit Menu 4.1

Automatic mode is the normal operating mode, in which the set times are taken into account. In continuous daytime or continuous nighttime mode, only the values set for daytime or nighttime mode are valid. In reference mode, the controller operates with a fixed flow temperature independently of the outdoor temperature. In “Off” mode the heating circuit is switched off completely.

*Setting range: Automatic, Continuous day, Continuous night, Reference, Off*

*Default setting: Automatic*

### 9.2 Domestic hot water Menu 4.2

Automatic mode is the normal operating mode, in which the set times are taken into account. In the operating mode “One”, the hot water charging is switched on continuously regardless of the set times, and in the operating mode “Off” the domestic hot water charging is switched off completely.

*Setting range: Automatic, On, Off*

*Default setting: Automatic*

## 9. Operating mode (continued)

### 9.3 Manual Menu 4.3

In Manual mode the individual relay outputs and the connected consumers can be checked for proper functioning and correct assignment.



**Danger**

The operating mode “Manual” may only be used by specialists for brief function tests, e.g. during commissioning!

When operating mode “Manual” is activated, the current temperatures and the selected parameters are no longer considered. There is therefore a danger of scalding or serious damage to the system.



**Caution**

In order to prevent icing of the evaporator, the compressor (relay R5) can only be switched on here if the glycol pump (relay R4) is switched on first.

Please also note that high-pressure faults may occur if the storage tank charging pump or if applicable the heating circuit pump is not also switched on at the same time.

Function in manual mode:

The relays and thus the connected consumer are switched on and off by pressing a key, with no regard to the current temperatures and the parameters which have been set. At the same time, the current measurement values of temperature sensors S1-S6 are also shown in the display for the purposes of function control.

## 10. Settings

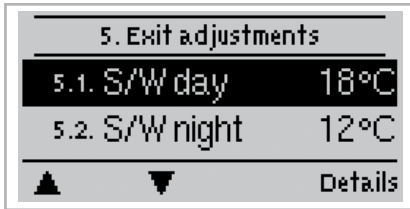

The necessary basic settings required for the control function are made in menu “5. Settings”.



Caution

This does not under any circumstances replace the safety facilities to be provided by the customer!

The menu is closed by pressing “esc” or selecting “Exit settings”.

### 10.1 Su/Wi day Menu 5.1 Summer/Winter changeover in daytime mode

If this value is exceeded at outdoor sensor S1 during the daytime mode times, the controller automatically switches the heating circuit off = Summer mode.

If the outdoor temperature drops below this value, the heating circuit is switched on again = Winter mode.

*Setting range: from 0 C to 30 C / default setting: 18 C*



Caution

In addition to the operating times in normal daytime operation, this setting is also valid for times with activated comfort temperature boost and activated low-rate period boost.

### 10.2 Su/Wi night Menu 5.2 Summer/Winter changeover in nighttime mode

If this value is exceeded at outdoor sensor S1 during the nighttime mode times, the controller automatically switches the heating circuit off = Summer mode.

If the outdoor temperature drops below this value, the heating circuit is switched on again = Winter mode.

*Setting range: from 0 C to 30 C / default setting: 12 C*

### 10.3 Min. flow Menu 5.3 minimum flow temperature

If the reference flow temperature calculated by the controller exceeds the value set here, the heating circuit is switched off, even if the heating circuit is in Winter mode due to the outdoor temperature. If the calculated reference flow temperature exceeds the set value, the heating circuit is switched on again.

*Setting range: from 5 C to 30 C / default setting: 15 C*

## 10. Settings (continued)

### 10.4 Slope Menu 5.4 slope of the heating characteristic curve

The characteristic is used to control the heat dissipation of the heating circuit as a function of the outdoor temperature. The following diagram shows the effect of the selected characteristic slope on the calculated reference flow temperature of the heating circuit. The correct characteristic is defined by the intersection of the calculated maximum flow temperature (design temperature) with the minimum outdoor temperature.

Example: Design temperature of the heater 60°C. Flow at lowest outdoor temperature according to heating demand calculation -12°C.

The intersection produces a slope of 1.2 as the setting value.

Setting range: from 0.0 to 2.5 / default setting: 0.8

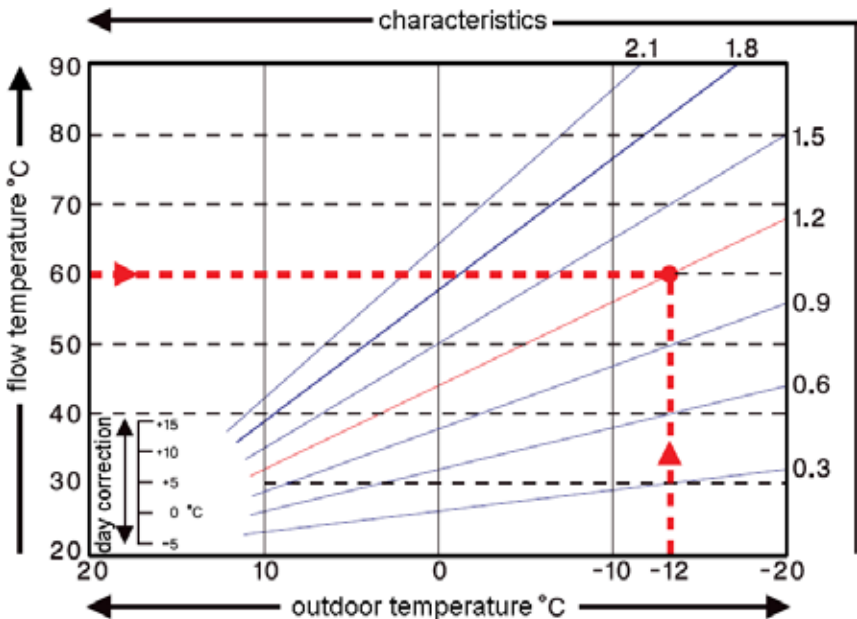

Caution

The following settings can be used for parallel translation of the characteristic for certain time periods such as daytime and night-time mode.

The calculated reference flow temperature is limited in the upwards direction by the setting for the maximum heating circuit temperature (11.3).

## 10. Settings (continued)

**10.6 Day correction Menu 5.6** parallel translation of the characteristic  
The day correction produces a parallel translation of the heating characteristic during the daytime operating hours, since depending on the outdoor temperature it is possible that the building may not be optimally heated with the set characteristic. If the characteristic is not optimised, the following situation may occur:

in hot weather - the spaces are too cold

in cold weather - the spaces are too hot

In this case, one should gradually reduce the characteristic slope in steps of 0.2, each time raising the day correction by 2-4 °C.

This procedure can be repeated several times as needed.

*Setting range: from -10 C to 50 C / default setting: 5*

**10.7 Night correction Menu 5.7** parallel translation of the characteristic  
The night correction produces a parallel translation of the heating characteristic during the nighttime operating hours. If a negative value is set for the night correction, the reference flow temperature is lowered accordingly during the nighttime operating hours. In this manner, primarily at night, but also during the day when no-one is at home, the room temperature is lowered, thus saving energy.

Example: A day correction of +5°C and a night correction of -2°C produces a reference flow temperature in nighttime operation that is 7°C lower.

*Setting range: from -30 C to 30 C / default setting: -2 C*

**10.8 Comfort temperature boost Menu 5.8** parallel translation of the characteristic

The comfort temperature boost is added to the set day correction. In this manner it is possible to carry out quick heating and/or a higher temperature in the living spaces at a certain time each day.

*Setting range: from 0 C to 15 C / default setting: 0 C = off*

**10.9 Low-rate period boost Menu 5.9** parallel translation of the characteristic  
The low-rate period boost is added to the set day correction. In this manner it is possible, for example, to ensure greater buffer or heating circuit heating during the low-rate periods.

*Setting range: from 0 C to 15 C / default setting: 0 C = off*



Caution

Specification of the operating times for the previously set values (10.6-10.9) is described in greater detail under 8.2-8.4.

## 10. Settings (continued)

### 10.10 Reference/actual - Menu 5.10 hysteresis for switching on the heat pump

This value is used to define by how much the heating circuit temperature may drop below the calculated reference flow temperature. If the heating circuit temperature drops below the reference flow temperature by the value set here, then the heat pump, and if applicable the buffer charging pump, are switched on.

*Setting range: from -1 C to -10 C / default setting: -2 C*

### 10.10 Reference/actual + Menu 5.11 hysteresis for switching off the heat pump

This value is used to define by how much the heating circuit temperature may exceed the calculated reference flow temperature. If the heating circuit temperature exceeds the reference flow temperature by the value set here, then the heat pump, and if applicable the buffer charging pump, are switched off.

*Setting range: from 1 C to 10 C / default setting: 2 C*



**Caution**

The following three setting only appear in the hydraulic variants 3, 4 and 5 with domestic hot water storage tank.

### 10.12 Domestic hot water min Menu 5.12 minimum domestic hot water temperature

If the set temperature in the domestic hot water storage tank is undershot and the domestic hot water heating has been enable for this time, then the heat pump and the storage tank charging pump switch on, as well as the valve if applicable.

*Setting range: from 10 C to 60 C / default setting: 45 C*

### 10.13 Domestic hot water heating Menu 5.13

The domestic hot water heating is switched off when the temperature in the domestic hot water storage tank reaches the minimum domestic hot water temperature plus the heating set here.

*Setting range: from 2 C to 20 C / default setting: 10 C*

### 10.14 Domestic hot water heating for low-rate period Menu 5.14 domestic hot water heating, low-rate period

With the value set here it is possible, for example, to ensure greater domestic hot water heating during the low-rate periods. The domestic hot water heating is only switched off when the temperature in the domestic hot water storage tank reaches the minimum domestic hot water temperature plus the heating for low-rate period set here.

*Setting range: from 0 C to 30 C / default setting: 0 C = off*



**Caution**

Specification of the operating times for the previously set values (10.12-10.14) is described in greater detail under 8.5-8.7.

## 11. Protective functions



Menu “6. Protective functions” can be used by specialists to activate and set various protective functions.



**Caution**

This does not under any circumstances replace the safety facilities to be provided by the customer!

The menu is closed by pressing “esc” or selecting “Exit settings”.

### 11.1 Anti-seizing protection Menu 6.1

If the anti-seizing protection is activated, then the controller switches the consumers on relays R1 to R4 on sequentially every day at at 15:00 and on Sundays at 15:00 for 5 seconds in order to prevent the pump and/or the valve from sticking after an extended stationary period. There is no anti-seizing function for the compressor on relay R5.

*Setting range: daily, weekly, off / default setting: daily*

### 11.2 Frost protection Menus 6.2 / 6.2.1 - 6.2.2

A frost protection function can be activated for the heat pump.

If the glycol return temperature drops below the value set here, the controller switches the heat pump (glycol pump+compressor) off until the glycol return temperature is once again above the set value by at least 2°C.

*Frost protection setting range: on, off / default setting: off*

*Frost stage 1 setting range: from -25 C to 5 C / default setting: 0 C*



**Caution**

The frost protection function only functions if glycol return sensor S5 is installed.

### 11.3 Max. heating circuit Menu 6.3

This value is used to limit the reference flow temperature and the heating for all heating circuit functions. If the heating circuit temperature nevertheless exceeds the set value, then the heating circuit and the heat pump are switched off until the temperature one again falls below this value.

*Setting range: from 30C to 80 C / default setting: 45 C*



**Caution**

For safety, the customer must provide an additional limiting thermostat which is connected to the pumps in series.

## 11. Protective functions (continued)

### 11.3 Max. domestic hot water Menu 6.4

This value is used to set an upper limit for the permissible domestic hot water heating. A proper setting will prevent a high-pressure fault from occurring in the heat pump, for example.

*Setting range: from 45 C to 90 C / default setting: 63 C*



**Danger**

The setting value limits the temperature for all domestic hot water function, including the anti-Legionella function.

A temperature setting that is too high can lead to scalding and damage to the system.

### 11.5 Anti-Legionella Menus 6.5 / 6.5.1 - 6.5.3)

With the “AL function” activated the controller makes it possible to heat the domestic hot water storage tank up at certain times to a higher temperature, assuming that the energy that is fed allows this.

*AL function setting range: On or Off / default setting: Off*

*AL TRef setting range: from 60 C to 70 C / default setting: 63 C*



**Caution**

The anti-Legionella function is switched off at delivery.

When heating-up has been carried out with the anti-Legionella function switched on, an information message with the date appears under menu item 6.5.3 . The operating times for the anti-Legionella function must also be defined (see 8.3)



**Danger**

During the anti-Legionella function the storage tank is heated up over the normal domestic hot water temperature, which can lead to scalding and damage to the system.



**Caution**

This function does not provide complete protection against Legionella, because the controller is dependent on sufficient energy being fed in, and it is not possible for the controller to monitor the temperatures in the entire range of the storage tanks and the connected piping system.

To provide complete protection against Legionella bacteria, it must be ensured that the temperature is raised to the necessary temperature, and at the same time there must be water circulation in the storage tank and piping system by means of other additional energy sources and control units.

## 12. Special functions



Menu “7. Special functions” is used to set basic items and expanded functions.



### Caution

The settings in this menu should only be made by a specialist.

The menu is closed by pressing “esc” or selecting “Exit special functions”.

### 12.1 Program selection Menu 7.1

The suitable hydraulic variant for the specific application is selected and set here (see 2.5 Hydraulic variants). The associated diagram can be displayed by pressing “info”.

*Setting range: 1-5/ default setting: 1*



### Caution

Normally the program selection is made only once during initial commissioning by the specialist. Incorrect program selection can lead to unpredictable errors.

### 12.2 Heat quantity Menu 7.2

When “Heat quantity” is selected, sensor 3 must be mounted in the return in such a way that simple acquisition of the heat quantity can be implemented. Additional information is required regarding any antifreeze and the flow rate of the system (glycol) in litres/hour.

*Heat metering setting range: Yes or No / default setting: No*

*Glycol type setting range: ethylene, propylene / default setting ethylene*

*Glycol portion setting range: 0...60% / default setting 40%*

*Flow rate setting range: 10...20000 l/h / default setting 3000 l/h*



### Caution

Sensors S5 glycol flow and S6 glycol return must be installed for heat metering. The data obtained from heat metering are merely guide values with no guarantee of accuracy. The data are output in the Statistics menu.

### 12.3 Sensor calibration Menus 7.3 / 7.3.1 - 7.3.3

Deviations in the temperature values displayed, for example due to cables which are too long or sensors which are not positioned optimally, can be compensated for manually here. The settings can be made for each individual sensor in steps of 0.5°C.

*Offset S1...S6 per setting range: -50 C...+50 C default setting: 0 C*



Settings are only necessary in special cases at the time of initial commissioning by the specialist. Incorrect measurement values can lead to unpredictable errors.

### 12.4 Commissioning Menu 7.4

Starting the commissioning help guides you in the correct order through the basic settings necessary for commissioning, and provides brief descriptions of each parameter in the display.

Pressing the “esc” key takes you back to the previous value so you can look at the selected setting again or adjust it if desired. Pressing the “esc” more than once takes you back to the selection mode, thus cancelling the commissioning help. (see also 5.1)



May only be started by a specialist during commissioning! Observe the explanations for the individual parameters in these instructions, and check whether further settings are necessary for your application.

### 12.5 Factory settings Menu 7.5

All of the settings that have been made can be reset, thus returning the controller to its delivery state.



The entire parametrisation, statistics, etc. of the controller will be lost irrevocably. The controller must then be commissioned once again.

### 12.6 Expansions Menu 7.6

This menu can only be selected and used if additional options or expansion modules have been built into the controller.

The associated supplementary installation, mounting and operation instructions are then included with the specific expansion.

### 12.7 Heat pump system Menus 7.7 / 7.7.1 - 7.7.6

The settings under this menu item and its four submenus should only be made by a specialist, since they have fundamental effects on the function of the heat pump and the connected system!

#### 12.7.1 Heat pump runtime Menu 7.7.1

After a heat demand, the compressor remains switched on for at least the time set here, even if the reference value has been reached.

*Setting range: from 0 to 30 minutes / default setting: 10 minutes*

 If a switch-off condition from one of the protective functions set under 11. is present, the compressor switches off, even if the minimum runtime has still not been reached.

#### 12.7.2 Heat pump idle time Menu 7.7.2

After previous operation, the compressor remains switched off for at least the time set here, even if there is a demand.

*Setting range: from 0 to 30 minutes / default setting: 10 minutes*

#### 12.7.3 Heat pump delay Menu 7.7.3

When there is a heat demand, first the glycol pump, and if applicable, the storage tank charging pump and domestic hot water pump/valve is switched on for the time set here. Only after that is the compressor switched on.

*Setting range: from 0 to 300 seconds / default setting: 20 seconds*

#### 12.7.4 Glycol overrun Menu 7.7.4

When the compressor is switched off, the glycol pump continues to run for the time set here, and then switches off.

*Setting range: from 0 to 300 seconds / default setting: 20 seconds*

#### 12.7.5 Storage tank charging pump (SCP) overrun Menu 7.7.5

When the compressor is switched off, the storage tank charging pump continues to run for the set time in order to remove the residual heat from the heat pump.

*Setting range: from 0 to 300 seconds / default setting: 20 seconds*

#### 12.7.6 Heating circuit pump Menu 7.7.6

This setting is used to define whether the heating circuit pump is only dependent on the outdoor temperature (summer/winter changeover=SW), or should also be switched off if the reference value is exceeded (Flow=VL).

If flow is selected, the times set under 12.7.3-12.7.5 are valid; they apply to both the storage tank charging pump and the heating circuit pump.

*Setting range: SW or VL (flow) / default setting: SW*

 If VL is set, the heating circuit pump is switched on in winter mode every 15 minutes in order to update the temperature value at the heating circuit sensor. If the heating circuit sensor is installed in the buffer storage tank, only the setting SW should be selected!

**13****Menu lock Menu 8****13****13. Menu lock**

Menu “8. Menu lock” can be used to secure the controller against unintentional changing and compromise of basic functions.



The menu is closed by pressing “esc” or selecting “Exit menu lock”.

The menus listed below remain completely accessible despite the menu lock being activated, and can be used to make adjustments if necessary:

1. Measurement values
2. Statistics
3. Times
5. Settings
8. Menu lock
9. Service values

To block the other menus, select “Menu lock on”.

To enable the menus again, select “Menu lock off”.

*Setting range: on, off / default setting: off*

**14****Language Menu 10****14****14. Language**

Menu “10. Language” can be used to select the language for the menu guidance. This is queried automatically during initial commissioning. The choice of languages may differ, however, depending on the device design. Language selection is not available in every device design!



## 15. Service values

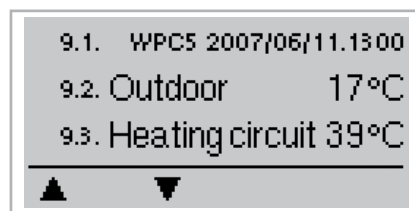

Menu "9. Service values" can be used for remote diagnosis by a specialist or the manufacturer in the event of an error, etc.



Enter the values at the time when the error occurs e.g. **Caution** in the table.



The menu can be closed at any time by pressing "esc".

9.1		9.31		9.61	
9.2		9.32		9.62	
9.3		9.33		9.63	
9.4		9.34		9.64	
9.5		9.35		9.65	
9.6		9.36		9.66	
9.7		9.37		9.67	
9.8		9.38		9.68	
9.9		9.39		9.69	
9.10		9.40		9.70	
9.11		9.41		9.71	
9.12		9.42		9.72	
9.13		9.43		9.73	
9.14		9.44		9.74	
9.15		9.45		9.75	
9.16		9.46		9.76	
9.17		9.47		9.77	
9.18		9.48		9.78	
9.19		9.49		9.79	
9.20		9.50		9.80	
9.21		9.51		9.81	
9.22		9.52		9.82	
9.23		9.53		9.83	
9.24		9.54		9.84	
9.25		9.55		9.85	
9.26		9.56		9.86	
9.27		9.57		9.87	
9.28		9.58		9.88	
9.29		9.59		9.89	
9.30		9.60		9.90	

### 16.1 Malfunctions with error messages

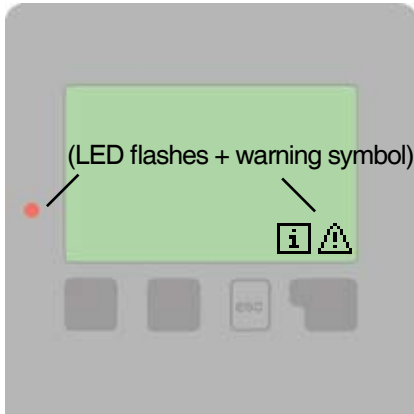

If the controller detects a malfunction, the red light flashes and the warning symbol also appears in the display. If the error is no longer present, the warning symbol changes to an info symbol and the red light no longer flashes.

To obtain more detailed information on the error, press the key under the warning or info symbol.



**Danger**

Do not try to deal with this yourself.

Consult a specialist in the event of an error!

Notes for the specialist:

Possible error / information messages:

Sensor x defective —————>

Means that either the sensor, the sensor input at the controller or the connecting cable is/was defective. (Resistance table on page 5)

Frost protection —————>  
(Information message only)

Means that the temperature at the glycol return is/was below the frost protection temperature set in menu 6.2.

Max. heating circuit —————>  
(Information message only)

Means that the maximum temperature is/was below the maximum heating circuit temperature set in menu 6.3.

Max. domestic hot water —————>  
(Information message only)

Means that the maximum temperature is/was below the maximum domestic hot water temperature set in menu 6.4.

Restart —————>  
(Information message only)

Means that the controller was restarted, for example due to a power failure. Check the date&time!

### 16.2 Replacing the fuse



**Danger**

Repairs and maintenance may only be performed by a specialist. Before working on the unit, switch off the power supply and secure it against being switched on again! Check for the absence of power!



**Danger**

Only use the supplied spare fuse or a fuse of the same design with the following specifications: T2A 250V

**Fig. 3.1.1**

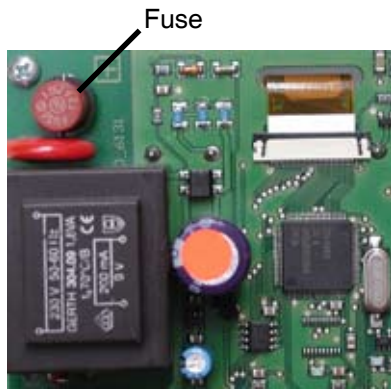

If the mains voltage is switched on and the controller still does not function or display anything, then the internal device fuse may be defective. In that case, open the device as described under 3.1, remove the old fuse and check it.

Exchange the defective fuse for a new one, locate the external source of the error (e.g. pump) and exchange it.

Then first recommission the controller and check the function of the switch outputs in manual mode as described under 9.3.

### 16.3. Maintenance



**Caution**

In the course of the general annual maintenance of your heating system you should also have the functions of the controller checked by a specialist and have the settings optimised if necessary.

Performing maintenance:

- Check the date and time (see 8.1)
- Assess/check plausibility of statistics (see 7.)
- Check the error memory (see 7.5)
- Verify/check plausibility of the current measurement values (see 6.)
- Check the switch outputs/consumers in manual mode (see 9.3)
- Poss. optimise the parameter settings





The **service values** (see 15.) include not only current measurement values and operating states, but also all of the settings for the controller. Write the service values down just once after commissioning has been successfully completed.



In the event of uncertainty as to the control response or malfunctions the service values are a proven and successful method for remote diagnosis. Write the service values down (see 15.) at the time that the suspected malfunction occurs. Send the **service value table** by fax or e-mail with a brief description of the error to the specialist or manufacturer.



The controller provides the option of switching the **heating circuit pump** depending on the outdoor temperature (summer/winter changeover) or when the reference value is undershot or overshot. (see menu 12.7.6).



To protect against loss of data, record any **statistics** and data that are particularly important to you (see 7.) at regular intervals.



The **operating hours** displayed in the „Statistics“ menu should only take into account the actual operating time of the compressor. In order not to take into account any times in which the heat pump is blocked, e.g. by a mains disconnect, the controller compares the glycol flow temperature with the glycol return temperature to check whether the compressor is actually switched on.



The remote adjuster **RT21**, which can be connected as an option, can be used from the living space to carry out a parallel translation of the heating characteristic, thus affecting the living space temperature quickly and easily.



Ask your power utility what their **low-rate periods are**. To save operating costs, the controller provides the option of carrying out increased storage tank charging at certain times (see 8.4 and 8.6).



---

Hydraulic variant set:

Commissioned on:

Commissioned by:

---

Notes:

---

Final declaration:

Although these instructions have been created with the greatest possible care, the possibility of incorrect or incomplete information cannot be excluded. Subject as a basic principle to errors and technical changes.

---

<p>Manufacturer: SOREL GmbH Mikroelektronik Jahnstr. 36 D - 45549 Sprockhövel Tel. +49 (0)2339 6024 Fax +49 (0)2339 6025 www.sorel.de info@sorel.de</p>	<p>Your specialist dealer:</p>
---	--------------------------------